

# **Technical Handbook - Domestic**

---

## Technical Handbook - Domestic

---

---

# Table of Contents

Technical Handbook - Domestic .....	1
4. Safety .....	2
4.0 Introduction .....	2
4.1 Access to buildings .....	4
4.2 Access within buildings .....	11
4.3 Stairs and ramps .....	18
4.4 Pedestrian protective barriers .....	31
4.5 Electrical safety .....	33
4.6 Electrical fixtures .....	35
4.7 Aids to communication .....	37
4.8 Danger from accidents .....	37
4.9 Danger from heat .....	42
4.10 Fixed seating .....	47
4.11 Liquefied petroleum gas storage .....	47
4.12 Vehicle protective barriers .....	52
4.13 Security .....	53
4.14 In-building physical infrastructure for high-speed electronic communications network .....	56

---

# Technical Handbook - Domestic

---

---

# Safety

## 4.0 Introduction

### 4.0.1 Background

Safety has been defined by the International Standards Organisation as 'a state of freedom from unacceptable risks of personal harm'. This recognises that no activity is absolutely safe or free from risk. No building can be absolutely safe and some risk of harm to users may exist in every building. Building standards seek to limit risk to an acceptable level by identifying hazards in and around buildings that can be addressed through the Building (Scotland) Regulations.

Deaths and serious injury to people in and around buildings occur in significant numbers from accidents involving falls, collisions, entrapment, scalding, electrocution or malfunction of fittings. Designers need to consider all aspects of design carefully to minimise risks inherent in any building.

Not all issues relating to good practice are covered in this Technical Handbook. Publications by organisations including the Royal Society for Prevention of Accidents (RoSPA) <http://www.rospa.com/> may offer further information relevant to the safety of occupants of, and visitors to, buildings.

**Accessibility** - buildings should be designed to consider safety and the welfare and convenience of building users. An inclusive environment is one within which everyone, regardless of age, disability or circumstance, can make use of facilities safely, conveniently and without assistance to the best of their ability. Buildings that consider future flexibility of use also contribute to the creation of a more sustainable housing stock, simplifying alterations. This can allow people to remain longer in their home, through changing circumstances, with the minimum of disruption and inconvenience.

The guidance in this section, together with the guidance in Section 3, Environment relating to accessibility, has been based around, and developed from, issues that are included in 'Housing for Varying Needs' and the Lifetime Homes concept developed by the Joseph Rowntree Foundation.

**Access statements** - many designers and developers are familiar with the use of an access statement as a means of assisting in the delivery of more inclusive buildings. This records how access issues have been considered and developed from project inception, through all stages of development, through to the final use of a building.

Where design proposals vary from guidance within this Handbook or, in the case of a conversion where a standard is to be met as far as is reasonably practicable, relevant information extracted from a project access statement may assist in determining compliance.

**Security** - a dwelling that is safe and secure provides a positive contribution to the quality of life of its occupants and contributes to the delivery of a more sustainable community. Introducing basic measures to improve security can make unlawful entry into dwellings physically more difficult and ensure the safety and welfare of occupants.

### 4.0.2 Aims

The intention of this section is to give recommendations for the design of buildings that will ensure access and usability, reduce the risk of accident and unlawful entry. The standards within this section:

- ensure accessibility to and within buildings and that areas presenting risk through access are correctly guarded, and
- reduce the incidence of slips, trips and falls, particularly for those users most at risk, and
- ensure that electrical installations are safe in terms of the hazards likely to arise from defective installations, namely fire and loss of life or injury from electric shock or burns, and
- prevent the creation of dangerous obstructions, ensure that glazing can be cleaned and operated safely and to reduce the risk of injury caused by collision with glazing, and
- safely locate hot water and steam vent pipe outlets, and minimise the risk of explosion through malfunction of unvented hot water storage systems and prevent scalding by hot water from sanitary fittings, and
- ensure the appropriate location and construction of storage tanks for liquefied petroleum gas, and
- ensure that windows and doors vulnerable to unlawful entry are designed and installed to deter house breaking.

### 4.0.3 Latest changes

The following is a summary of the changes that have been introduced since 1 October 2015.

- **Standard 4.14** - Introduction of a new standard and supporting guidance covering the provision of in-building physical infrastructure to facilitate the installation of high-speed electronic communications networks.
- **Appendix A** - Additional defined terms added. Most of these new terms are as defined within Article 2 of EU Directive 2014/61/EU.

### 4.0.4 Relevant legislation

Listed below are some pieces of legislation that may be relevant and/or helpful to those using the guidance in this particular section.

The Electricity Safety, Quality and Continuity Regulations 2002 defines the duties of any party supplying electricity to premises with regard to matters such as supply, equipment, protection and provision of earthing.

The Gas Safety (Installations and Use) Regulations 1998 require that any person who installs, services, maintains, removes, or repairs gas fittings must be competent. It covers not only materials, workmanship, safety precautions and testing of gas fittings but also the safe installation of all aspects of gas-fired combustion appliance installations.

### 4.0.5 Certification

Scottish Ministers can, under Section 7 of the Building (Scotland) Act 2003, approve schemes for the certification of design or construction for compliance with the mandatory functional standards. Such schemes are approved on the basis that the procedures adopted by the scheme will take account of the need to co-ordinate the work of various designers and specialist contractors. Individuals approved to provide certification services under the scheme are assessed to ensure that they have the qualifications, skills and experience required to certify compliance for the work covered by the scope of the

scheme. Checking procedures adopted by Approved Certifiers will deliver design or installation reliability in accordance with legislation.

The certification of construction (electrical installations to BS 7671) scheme has been approved by Scottish Ministers to confirm compliance with relevant standards in Section 4. <http://www.scotland.gov.uk/topics/built-environment/building/building-standards>.

## 4.1 Access to buildings

### Mandatory Standard

#### **Standard 4.1**

**Every building must be designed and constructed in such a way that all occupants and visitors are provided with safe, convenient and unassisted means of access to the building.**

#### **Limitation:**

There is no requirement to provide access for a wheelchair user to:

- a. a house, between either the point of access to or from any car parking within the curtilage of a building and an entrance to the house where it is not reasonably practicable to do so, or
- b. a common entrance of a domestic building not served by a lift, where there are no dwellings entered from a common area on the entrance storey.

### 4.1.0 Introduction

An inclusive approach to design should be taken to ensure that buildings are as accessible to as wide a range of people as possible. Solutions should be integral to a design rather than an afterthought added in order to meet duties under building standards or other legislation.

**Inclusive design** is not just relevant to buildings. It applies throughout any internal or external environment, wherever people go about everyday activities. It should be a continuous process, through all stages of the development of a building and involve potential users. Advice on this topic is available in the joint BSD/Scottish Executive Planning Division Planning Advice Note PAN 78: 'Inclusive Design' which promotes the merits of an inclusive approach to the design of the built environment.

Whilst the guidance to this standard reflects general good practice, certain issues remain outwith the scope of the building regulations. There are numerous publications offering additional guidance on accessibility and inclusive design, including those listed below:

- BS 8300: 2009 – 'Design of buildings and their approaches to meet the needs of disabled people – code of practice'
- Housing for Varying Needs, Parts 1 & 2 - Communities Scotland
- 'Inclusive Mobility' – Department of Transport, 2002
- 'Guidance on the Use of Tactile Paving Surfaces', published jointly by The Scottish Office and the Department for the Environment, Transport and the Regions (DETR).

**Conversions** - in the case of conversions, as specified in regulation 4, the building as converted shall meet the requirements of this standard in so far as is reasonably practicable, and in no case be worse than before the conversions (regulation 12, schedule 6).

### 4.1.1 Accessible car parking to flats or maisonettes

The need for car parking serving a domestic building will commonly be determined by a developer and may also be a condition of planning permission. Where car parking is provided within the curtilage of a building containing flats or maisonettes, it should include accessible spaces.

A proportion of car parking spaces should be designed to be accessible to a person with mobility impairment, including a wheelchair user, and designated for use as such. These parking spaces should be:

- a. provided on a ratio of at least 1 per 20 parking spaces, or part thereof, and
- b. located on a road surface that is level (with a gradient of not more than 1 in 50), and
- c. not more than 45m from a common entrance, and
- d. clearly marked with the international symbol of access, and
- e. provided with a dropped kerb access to an accessible route, and
- f. where perpendicular or at an angle to a road, at least 4.8m long x 2.4m wide, outwith which a delineated access zone at least 1.2m wide to each long side and between the end of the bay and any road is shown, or
- g. where parallel to a road, at least 6.6m long by 3.6m wide, as shown below.

**Figure 4.1 Off- and on-street accessible car parking**

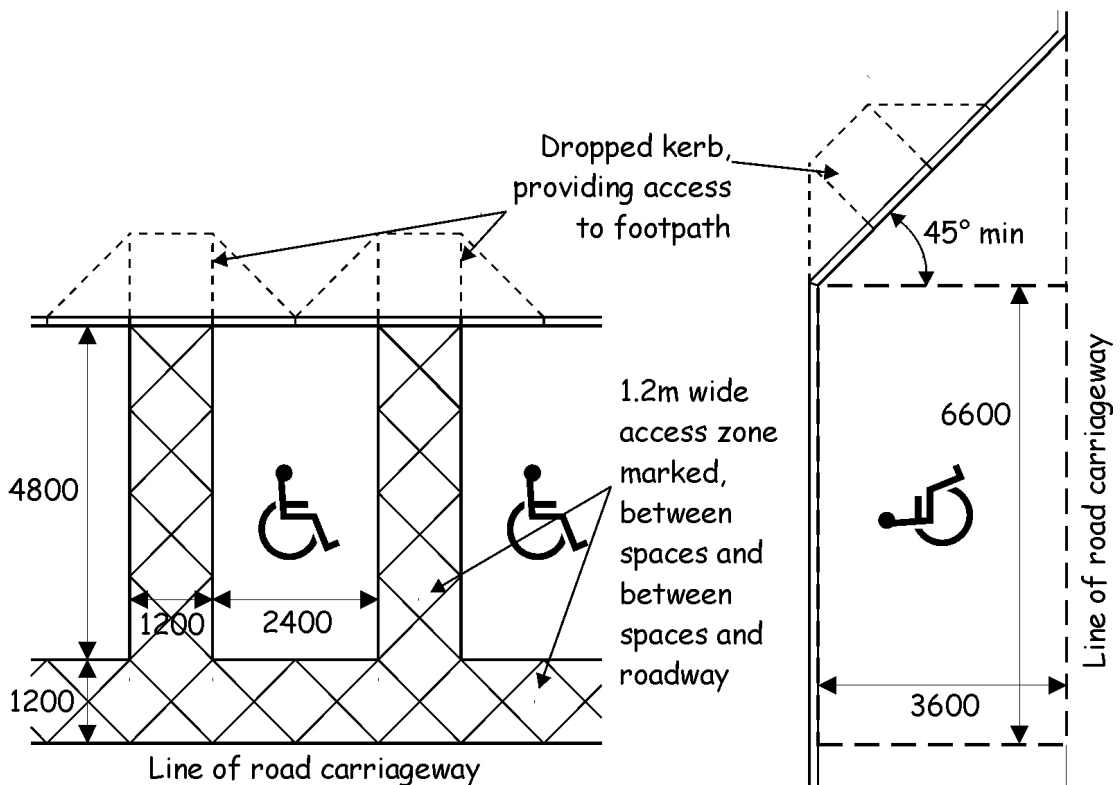

## 4.1.2 Car parking within the curtilage of a dwelling

Where car parking is provided within the curtilage of a dwelling, a person should be able to alight from a vehicle directly onto the firm surface of an accessible route to the dwelling.

Where a driveway or car parking space forms part of an accessible route to a dwelling, it should be at least 3.3m wide to allow a 900mm wide pedestrian route past a parked car. That portion of the driveway surface should be in accordance with the recommendations in clause 4.1.4.

## 4.1.3 Accessible routes

Regardless of how they arrive within the curtilage of a building, a person should then be able to travel conveniently and without assistance to an entrance of a building. Routes to a building that are too steep, too narrow or poorly surfaced, or that contain steps or other obstructions, will make access difficult or impossible for many people. To prevent this, a route to an entrance should be provided that is accessible to everyone.

An accessible route should contain no barriers, such as kerbs, steps or similar obstructions that may restrict access. Street furniture can present a hazard, particularly to a wheelchair user or a person with a visual impairment and should be located outwith the width of an accessible route. Use of low-level bollards or chain-linked posts, for example, can be particularly hazardous.

There should be an accessible route to the accessible entrance of a single dwelling from:

- a road, and
- any car parking within the curtilage of the dwelling.

There should be an accessible route to the common entrance of a building containing flats or maisonettes and to an accessible entrance of any dwelling not reached through a common entrance, from:

- a road, and
- any accessible car parking (see clause 4.1.1) within the curtilage of the building.

**Gradient of accessible route** - as steeper gradients are more difficult to negotiate, level or gently sloping routes should be used where possible, in preference to ramps. An accessible route should be:

- level, which for the purpose of this guidance is a gradient of not more than 1 in 50, or
- gently sloping, which for the purpose of this guidance is a gradient of more than 1 in 50 and not more than 1 in 20, or
- ramped, with a gradient of more than 1 in 20 and not more than 1 in 12

The cross-fall on any part of an accessible route should not exceed 1 in 40.

**Gently sloping gradients** should be provided with level rest points of not less than 1.5m in length, at intervals dependent on the gradient of the sloping surface. This should follow the same relationship given for ramp flights, e.g. up to 20m apart for a slope of 1 in 30, 30m for a slope of 1 in 40 and so on.

Recommendations for ramps are provided in the guidance to Standard 4.3.

**Complementary steps** - ramps are not necessarily safe or convenient for an ambulant person with mobility impairment, and can be more difficult and dangerous to negotiate than steps. Therefore, on a route serving more than 1 dwelling, any ramped access, having a rise of more than 300mm, should be complemented by an alternate, stepped means of access.

There may be stepped access to a route serving a single house where it is not reasonably practicable to construct an accessible route, such as on a steeply sloping site. As a guideline, if a ramp to an accessible entrance can be formed within the curtilage of the dwelling with one change in direction between the bottom of the ramp and the top landing, access should be considered reasonably practicable.

Where an accessible route cannot be provided from a road, it may still be practicable to construct an accessible route by providing a car parking space within the curtilage of the dwelling. It is only where it is not reasonably practicable to construct an accessible route from either a road or from car parking within the curtilage of the dwelling that a stepped access solution may be proposed.

#### 4.1.4 Surface to accessible routes

For safety and convenience in use, the surface of an accessible route should be firm, uniform and of a material and finish that will permit ease in manoeuvring. It should provide a degree of traction that will minimise the possibility of slipping. This should take into account both anticipated use and environmental conditions.

The surface of an accessible route, whether composed of modular paving units, formless materials such as tarmac, or another durable material, should have a profile that will not offer a trip hazard or result in standing water. It should be installed in accordance with a code of practice relevant to the material, where such exists.

Surface elements such as drainage gratings and manhole covers should be of a type that will not create a trip or entrapment hazard. Uneven surfaces, such as cobbles, or loose-laid materials, such as gravel, will present difficulties to many people and should not be used.

**Tactile paving** - at a location where the footpath is level with a road surface, such as at a dropped kerb, tactile paving should be used to provide warning to a person with a visual impairment of the presence of a vehicular route. This need not apply to a route within the curtilage of a single dwelling. Information on use of tactile paving on footpaths is given in 'Guidance on the Use of Tactile Paving Surfaces'.

#### 4.1.5 Length of accessible routes

The longer a pedestrian route, the greater difficulty it can present to many people. Therefore, in addition to minimising gradients where possible, as recommended in clause 4.1.3, the length of an accessible route to an accessible entrance of a building should be limited to 45m.

#### 4.1.6 Width of accessible routes

The width of a pedestrian route to a building should reflect how it will be used. For example, most public footpaths are at least 1.8m wide, which allows two-way traffic under most circumstances.

The clear and unobstructed surface width of an accessible route should generally be at least 1.8m, unless:

- giving access to not more than 10 dwellings, where the minimum surface width may be not less than 1.2m. This will accommodate any person where traffic is in a single direction of travel. To allow for passing, localised widening of any route less than 1.8m wide to at least 1.8m should be made at any junction and change of direction and, where the whole length of the route is not visible, also at not more than 10m intervals along the route, or
- giving access to a single dwelling, where effective width may be not less than 900mm, recognising reduced levels of traffic.

On an accessible route serving more than one dwelling, a level footpath of not less than 1.0m in width should be maintained to the rear of the slope of any dropped kerb.

Any gate across an accessible route should offer a clear opening width of at least 850mm.

## 4.1.7 Accessible entrances

Each common entrance to a domestic building and at least one entrance to a dwelling should be an accessible, designed to present as little restriction to passage as possible.

Whilst an accessible entrance to a house is commonly the front or main entrance, an alternate entrance may be designated as the accessible entrance where this provides a more convenient or practical route into the dwelling.

An accessible entrance to a building should:

- have an unobstructed entrance platt of at least 1.2m by 1.2m, with a crossfall of not more than 1 in 50, if required to prevent standing water, and
- have a means of automatic illumination above or adjacent to the door, and
- have an accessible threshold, and
- have a door leaf giving a clear opening width of at least 800mm in accordance with the diagram below, and
- if fitted with a door closing device, be operable with an opening force of not more than 30N (for first 30° of opening) and 22.5N (for remainder of swing) when measured at the leading edge of any door leaf, and
- if not a powered door, have an unobstructed space to the opening face of the door, next to the leading edge, of at least 300mm.

However where there is not an accessible route to a single house, the guidance in sub clauses (a) and (c) above need not be followed.

**Figure 4.2 Accessible entrance door**

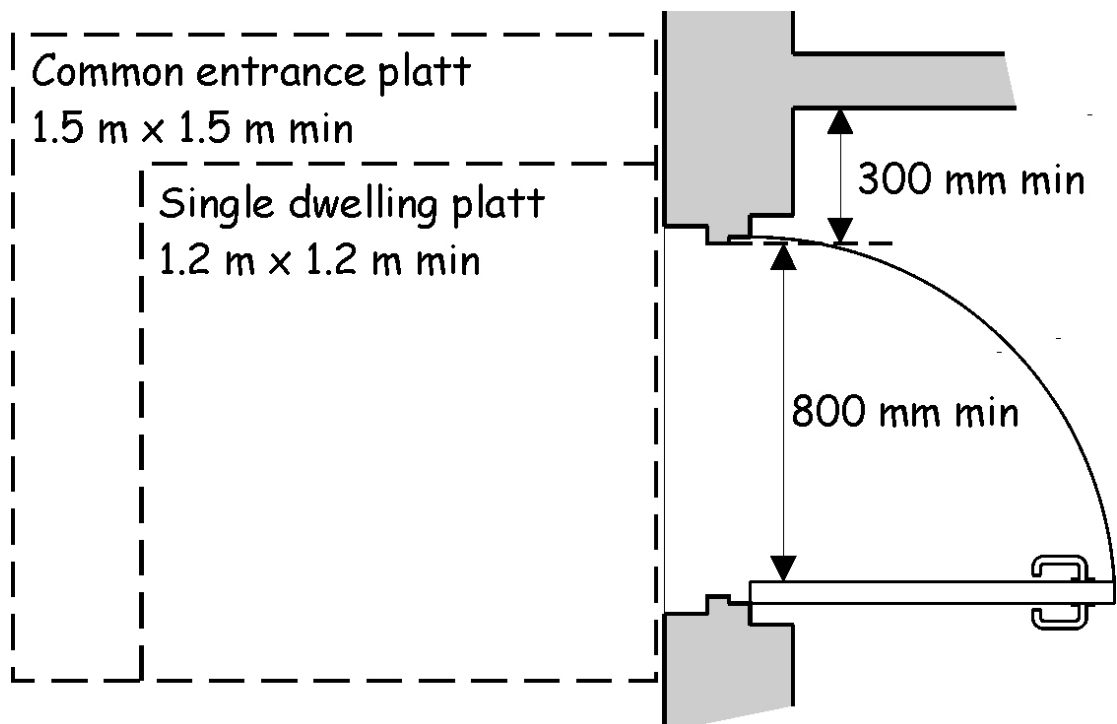

**Clear opening width** - the projection of ironmongery which extends across the width of a door leaf, such as an emergency push bar for escape or a horizontal grab rail, should be subtracted when calculating the clear opening width.

## 4.1.8 Common entrances

In addition to the recommendations in clause 4.1.7, a common entrance to a domestic building should have:

- an unobstructed entrance platt, measuring at least 1.5m by 1.5m, with a crossfall of not more than 1 in 50 if required to prevent standing water, and
- a canopy, recessed entrance or similar means of protecting people entering the building from exposure to the elements, and
- a glazed vision panel, as described below, and
- a door entry system.

**Weather protection** - the form that weather protection should take will vary with location and exposure of the building. However an example of minimum provision might be a canopy or recess, 750mm deep, across the width of the entrance platt, with an underside not more than 2.3m above entrance level. It is recognised that there are circumstances where provision of weather protection may not be practicable or may be constrained by other permissions.

**Glazed vision panels** - to assist in preventing collisions, a clear glazed vision panel or panels to a door should give a zone of visibility from a height of not more than 500mm to at least 1.5m above finished floor level. This may be interrupted by a solid element between 800mm and 1.15m above floor level. A vision panel is not needed to a powered door controlled by automatic sensors or where adjacent glazing offers an equivalent clear view to the other side of a door.

Guidance relevant to specific door types such as revolving doors or powered doors is given in the non-domestic Technical Handbook.

## 4.1.9 Accessible thresholds

To be accessible, a door should not present unnecessary barriers to use, such as a step or raised profile at a threshold that might present difficulties to a wheelchair user or be an entrapment or trip hazard to an ambulant person, whether or not using a walking aid.

**Figure 4.3 Generic threshold profile**

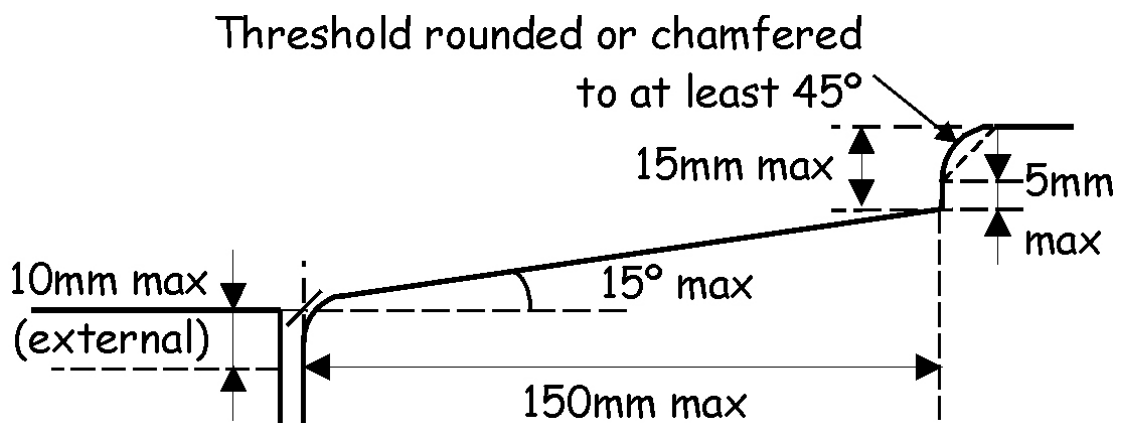

An accessible threshold should meet the following criteria:

- thresholds should be designed to prevent the ingress of rain. Details in the DETR publication 'Accessible Thresholds in New Housing' gives guidance on how this might be achieved
- externally, the surface of the platt should be not more than 10mm below the leading edge of any sill, with any exposed edge chamfered or rounded
- an external sill or internal transition unit should be at an angle of not more than 15° from the horizontal and, if sloping, be not more than 150mm in length
- the threshold should either be level or of a height and form that will neither impede unassisted access by a wheelchair user nor create a trip hazard. A threshold piece should have a height of not more than 15mm, with any vertical element of more than 5mm height being pencil-rounded or chamfered to an angle of not more than 45° from the horizontal
- if the finished internal floor level is more than 15mm below the top of the threshold, an internal transition unit, of not more than 15° to the horizontal, finishing not more than 5mm above the internal floor surface may be used, in accordance with the guidance above. In new buildings, this should normally only be needed to allow flexibility in subsequent fitting of differing thickness of floor coverings.

## **4.1.10 Alteration and extension**

Where a dwelling is altered or extended, this work should not adversely affect an existing accessible entrance.

Where a dwelling does not have an accessible entrance, one need not be provided to the existing dwelling, or to the extension, as this will not result in the building failing to meet the standard to a greater degree.

Where an accessible entrance exists, any works should ensure that the existing entrance remains accessible. If this is not possible, a new accessible entrance should be provided elsewhere into the dwelling. Such an entrance should also maintain accessibility within the dwelling, as set out in guidance to Standard 4.2.

## 4.2 Access within buildings

### Mandatory Standard

#### Standard 4.2

Every building must be designed and constructed in such a way that:

- a. in non-domestic buildings, safe, unassisted and convenient means of access is provided throughout the building
- b. in residential buildings, a proportion of the rooms intended to be used as bedrooms must be accessible to a wheelchair user
- c. in domestic buildings, safe and convenient means of access is provided within common areas and to each dwelling
- d. in dwellings, safe and convenient means of access is provided throughout the dwelling, and
- e. in dwellings, unassisted means of access is provided to, and throughout, at least one level.

#### Limitation:

There is no requirement to provide access for a wheelchair user:

- a. in a non-domestic building not served by a lift, to a room, intended to be used as a bedroom, that is not on an entrance storey, or
- b. in a domestic building not served by a lift, within common areas and to each dwelling, other than on an entrance storey.

### 4.2.0 Introduction

Circulation areas within a building should allow occupants to move around freely and without difficulty, to the best of their ability. Lack of space can make movement around a building difficult for many people and hamper activities such as carrying or moving large items.

The design process should consider how the building can be used by as wide a range of people as possible, including use by a person in a wheelchair, though it is recognised that this may not be to the optimum standard that can be achieved within purpose-built dwellings.

Improvement to circulation within dwellings under this standard, together with the provision, on one level, of an enhanced apartment, and kitchen (Standard 3.11) and accessible sanitary accommodation (Standard 3.12) will assist in creating more sustainable homes.

Whilst the guidance to this standard reflects general good practice, certain issues remain outwith the scope of the building regulations. There are numerous publications offering additional guidance on accessibility and inclusive design, including those listed below:

- BS 8300: 2009 – ‘Design of buildings and their approaches to meet the needs of disabled people – code of practice’

- Housing for Varying Needs, Parts 1 & 2 – Communities Scotland.

**Conversions** - in the case of conversions, as specified in regulation 4, the building as converted shall meet the requirements of this standard in so far as is reasonably practicable, and in no case be worse than before the conversion (regulation 12, schedule 6).

## 4.2.1 Horizontal circulation in common areas of domestic buildings

The common areas of domestic buildings containing flats or maisonettes, though secured against unauthorised entry, remain in effect a public or shared area. As an enclosed space, it is important that provisions made on the approach to the building are maintained within these areas.

There should be level or ramped access within the common areas of a domestic building:

- from a common entrance to the entrance of any dwelling or communal facilities on the entrance storey and to any passenger lift, and
- where a passenger lift is installed, from the passenger lift to any dwelling and to any communal facilities on an upper storey.

Circulation routes within common areas should allow safe and convenient passage and provide space for manoeuvring at junctions and when passing through doorways. All corridors therefore should have a minimum width of at least 1.2m.

To allow manoeuvring space for both people and furniture, routes should be widened locally, at changes of direction, junctions and at the landing of any lift, to accommodate, clear of any obstruction, a 1.5m turning circle.

**Obstructions** - other than on a wall opposite a doorway, or in the areas noted above, an obstruction such as a radiator may project up to 100mm, reducing corridor width to not less than 1.1m, over a maximum length of 900mm.

**Gently sloping surfaces** - within a building, unidentified gradients may disorient building users and the need for gently sloping surfaces on circulation routes should be considered carefully before use. Level rest points on gently sloping routes should be provided as recommended in clause 4.1.3. Where not extending across the full width of a room or corridor, guarding should be provided to any exposed edge of such an area as for a ramp flight, as noted in the guidance to Standard 4.4.

## 4.2.2 Floor surfaces in common areas of domestic buildings

Floor surfaces within common areas should be uniform, permit ease in manoeuvring and be of a material and finish that, when clean and dry, will provide a level of traction that will minimise the possibility of slipping.

Where there is a change in the characteristics of materials on a circulation route, such as from a tile to carpet finish, transition should be level and, where reasonably practicable, differing surfaces should contrast visually to identify the change in material and reduce the potential for trips.

## 4.2.3 Lobbies in common areas of domestic buildings

Use of a lobby can reduce the effect of external conditions on the interior of a building and may also contribute to fire safety. However where two sets of doors are in close proximity, this can present a hazard and a potential barrier to access.

Any lobby at the entrance to or within the common areas of a domestic building should allow a person to pass through whilst remaining clear of the swing of doors. A rectangular area, outwith any door swing, of at least 1.6m long by 750mm wide will permit safe passage of, for example, a person in a wheelchair and a companion.

**Figure 4.4 Accessible lobby dimensions**

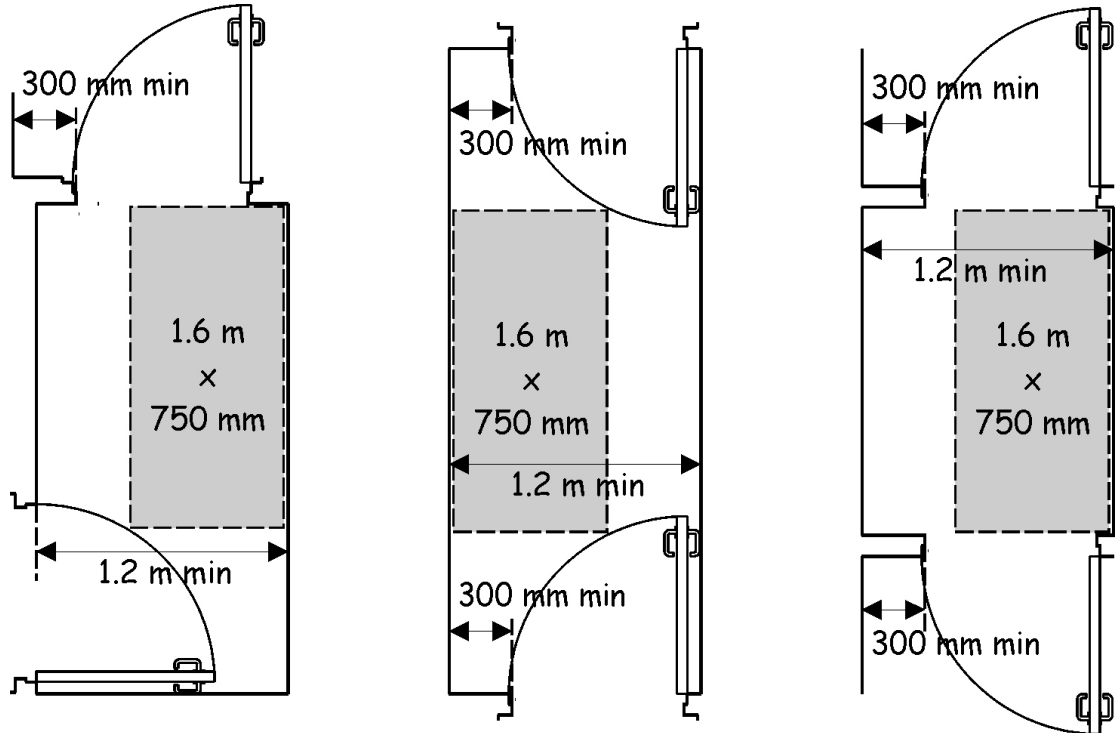

Where either door can be secured by a locking device, a lobby should be not less than 1.5m wide. This will permit a wheelchair or pram to be turned around should passage be denied.

## 4.2.4 Doors within common areas of a domestic building

Doors within the common areas of a domestic building should present as little restriction to passage as practicable and be constructed in a manner that does not present a hazard or a potential barrier to access.

A door located within the common areas of a domestic building should:

- a. if fitted with a threshold, have an accessible threshold, and
- b. have a door leaf giving a clear opening width in accordance with the table below, and
- c. where across a circulation route or giving access to communal facilities, have a glazed vision panel in any opening leaf, as described in clause 4.1.8, and
- d. have a door leaf that, if fitted with a door closing device, be operable with an opening force of not more than 30N (for first 30° of opening) and 22.5N (for remainder of swing) when measured at the leading edge of the leaf, and
- e. if not a powered door, have an unobstructed space to the opening face of the door, next to the leading edge, of at least 300mm.

**Table 4.1 Width of doors**

Minimum corridor width at door (mm)	Minimum clear opening width (mm) [1]
1500	800
1200	825 [2]
900 [3]	850 [2]

**Additional information:**

1. The projection of any ironmongery that extends across the width of a door leaf, such as an emergency push bar to a fire exit or horizontal grab rail, should be subtracted when calculating the clear opening width.
2. The clear opening width may be 800mm where a door is approached head-on.
3. A corridor width of less than 1.2m should not be present within new buildings but may be found within some existing buildings.

A door should not open onto a circulation route in a manner that creates an obstruction, other than a door to a cupboard or duct enclosure that is normally locked in a closed position.

## 4.2.5 Vertical circulation in common areas of domestic buildings

Stairs in common areas should be designed to be accessible to a person with reduced mobility, as described in guidance to Standard 4.3. There should be an accessible stair between each level of a building.

Level access, or access by a stair or ramp device should be provided to any storey, or part of a storey. However it is recognised that it may not be necessary or, in some cases, reasonably practicable to provide full access to all parts of a building. Consequently, such access need not be provided to any storey, or part of a storey:

- containing only fixed plant or machinery, the only normal visits to which are intermittent, for inspection or maintenance purposes, or
- where access is restricted to suitably trained persons for health and safety reasons, such as to walkways giving access only to machinery or to catwalks and working platforms, reached by industrial ladder.

**Installation of a passenger lift** will allow all dwellings on upper storeys to be reached from a common entrance level. However it is recognised that it may not always be reasonably practicable to provide lift access within all domestic buildings.

Therefore, a building containing flats or maisonettes may be constructed without a passenger lift where not more than 4 storeys in height and where there is no dwelling with a principal living level at more than 10m above either a common entrance level or the level of the lowest storey.

In any building above this height, or where there are communal facilities on a level other than a common entrance level, there should be a means of unassisted access. This should serve each level of the building that contains a common entrance, an entrance to a dwelling or communal facilities. Unassisted access between storeys should be by passenger lift, with the installation meeting the recommendations of BS EN 81-70: 2003.

Any passenger lift should be designed and installed to include the following:

- a. a clear landing at least 1.5m x 1.5m in front of any lift entrance door, and
- b. automatic lift door(s), with a clear opening width of at least 800mm, fitted with sensors that will prevent injury from contact with closing doors, and
- c. a lift car at least 1.1m wide by 1.4m deep, and
- d. within the overall dimensions of the lift car, a horizontal handrail, of a size and section that is easily gripped, 900mm above the floor on each wall not containing a door, and
- e. within a lift car not offering through passage, a mirror on the wall facing the doors, above handrail height, to assist a wheelchair user if reversing out, and
- f. within the lift car, tactile storey selector buttons and, in a lift serving more than 2 storeys, visual and voice indicators of the storey reached, and
- g. controls on each level served, between 900mm and 1.1m above the landing, and within the lift car on a side wall between 900mm and 1.1m above the car floor and at least 400mm from any corner, and
- h. on the landing of each level served, tactile call buttons and visual and tactile indication of the storey level, and
- i. lift doors, handrails and controls that contrast visually with surrounding surfaces, and
- j. a signalling system which gives notification that the lift is answering a landing call, and
- k. a system which permits adjustment of the dwell time after which the lift doors close, once fully opened, to suit the level of use, and
- l. a means of two way communication, operable by a person with a hearing impairment, that allows contact with the lift if an alarm is activated, together with visual indicators that an alarm has been sounded and received.

## 4.2.6 Accessibility within a storey of a dwelling

To ensure facilities within a dwelling can be reached and used by occupants, each storey within a dwelling should be designed to be accessible. There should be safe and convenient access to and throughout each storey other than to a level which comprises solely of storage and/or such accommodation as may be accessed via a 600mm wide stair.

Each accessible level or storey within a dwelling should have:

- a. corridors with an unobstructed width of at least 900mm wide. This may be reduced to 800mm over a maximum length of 900mm by permanent obstructions, such as radiators, or a future stair lift parking space, except on a wall opposite a doorway, and
- b. corridors that are large enough to accommodate an unobstructed area of 1.1m by 800mm which, where a door being used opens into the corridor, is oriented in the direction of entry and is clear of the door swing, and
- c. doors with a minimum clear opening width in accordance with the following table to each room, including any apartment, kitchen or sanitary facility.

**Table 4.2 Width of door openings**

Location	Minimum clear opening width
Door from a corridor with a minimum width of 1050mm	775mm

Location	Minimum clear opening width
Door from a corridor with a minimum width of 900mm	800mm [1]
Door between rooms	775mm
Door to en-suite sanitary accommodation	670mm

**Additional information:**

1. The opening width may reduce to 775mm where a door is approached head-on.

**Principal living level** - in addition, there should be unassisted access to the basic accommodation needed in any dwelling. The principal living level of a dwelling, normally also the entrance storey, should contain at least one enhanced apartment (see clause 3.11.2), a kitchen (see clause 3.11.3) and accessible sanitary accommodation (see clause 3.12.3). This accommodation should be either on one level or, if on different levels within a storey, accessible without a stepped change of level.

## 4.2.7 Access between storeys in a dwelling

Where a dwelling has accommodation on more than one level, the levels containing accommodation should be connected by a stair or ramp within the dwelling following the guidance given under Standard 4.3.

However the guidance under Standard 4.3 need not be applied to a fixed means of access leading only to a storey or level containing storage, though access to such a level must still meet Standard 4.3 and offer safe passage.

## 4.2.8 Unassisted access between storeys in a dwelling

Not everyone can use stairs unassisted. This may mean that the upper levels of a dwelling are not accessible to some occupants. Guidance elsewhere considers situations where occupants, incapacitated for a short period of time, might live within one storey. However this is not generally appropriate for longer term illness or infirmity, where a more permanent, inclusive, solution is required.

Provision should be made for future installation of a means of unassisted access, both within a storey and between storeys.

**To allow for future installation of a stair lift**, any stair giving access to a principal living level or to accommodation greater than may be accessed via a 600mm wide stair (see clause 4.3.3) should:

- have an area of wall not less than 700mm in length, or an equivalent space, adjacent to the bottom riser of a stair and clear of any obstruction, fitting or doorway, to allow for parking of a stair lift at rest position. This space should be not less than 400mm in depth, and
- have a similar area of not less than 200mm in length, on the same side of the flight, at landing level adjacent to the top nosing of the stair, to assist in transfer at the upper level, allowing for projection of a stair lift track.

**Figure 4.5 Future provision for unassisted access**

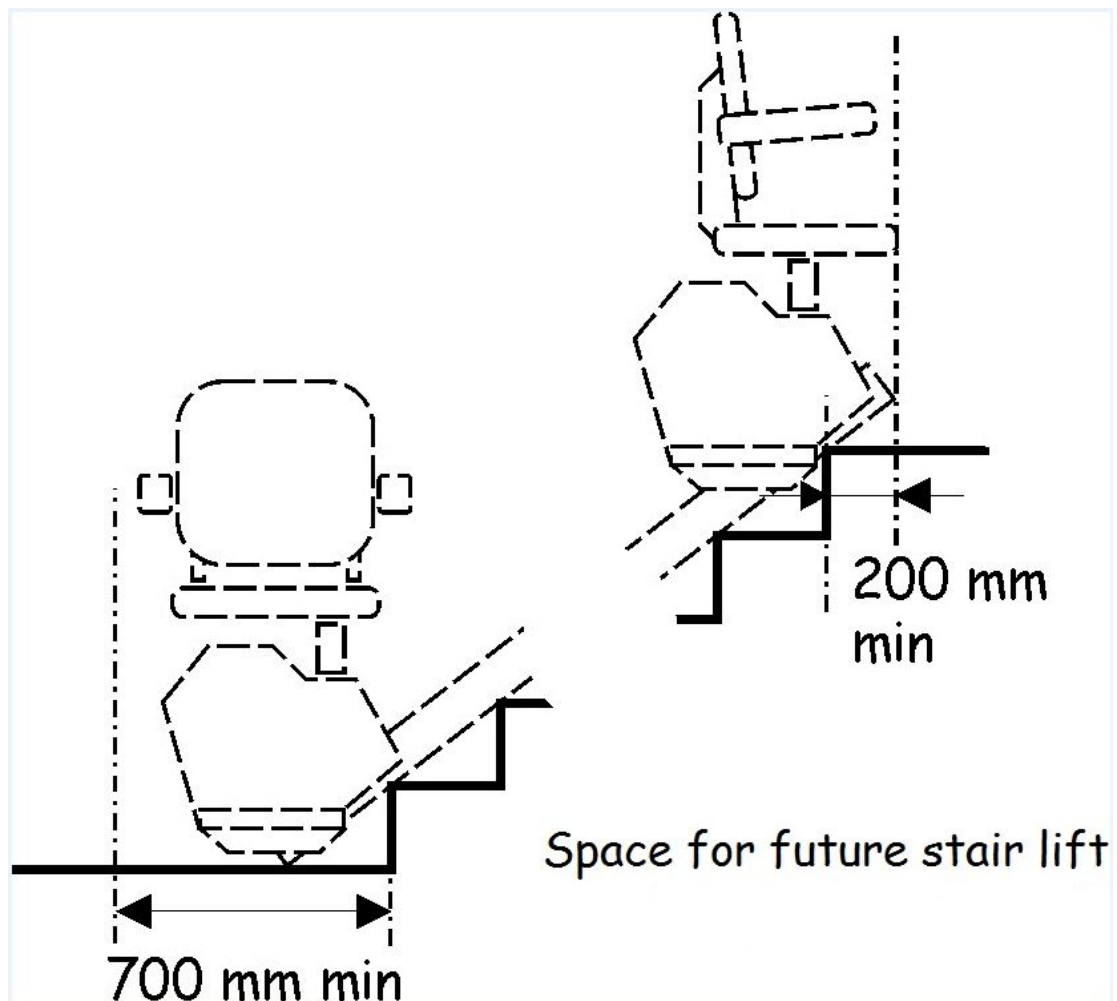

### 4.2.9 Split level storeys

Any change of level within a storey should not compromise access to facilities within the principal living level of a dwelling.

A storey may be split level provided a stepped change of level does not divide the accommodation forming the principal living level of a dwelling (see clause 4.2.6). In addition, if a stepped change of level is proposed on an entrance storey containing the principal living level, the route from the accessible entrance of the dwelling to the accommodation forming the principal living level should be without a stepped change of level.

### 4.2.10 Dwellings with limited entrance storey accommodation

Where a dwelling, such as a townhouse or upper villa flat, contains no, or only limited, accommodation on the entrance storey, this can make access to the basic facilities within the dwelling more difficult for many people.

Where the entrance storey of a dwelling is not also the principal living level, the first storey above or below entrance storey which contains an enhanced apartment, kitchen and accessible sanitary accommodation is considered to be the principal living level.

Where there is not level or ramped access from the accessible entrance of a dwelling to the principal living level, the principal living level should be made accessible to as wide a range of occupants as possible and, accordingly:

- a. a stair, from an accessible entrance to the principal living level, should follow the guidance on rise, going and pitch for 'any other stair' given in clause 4.3.2, and
- b. provision for installation of a stair lift should be made as described in clause 4.2.8, and
- c. entrance level accommodation should contain an area of at least 800mm wide by 1.1m long that would permit storage of a wheelchair or pram. This should be outwith the minimum corridor width noted in clause 4.2.6 and clear of any door way, door swing, stair landing or space identified for a future stair lift installation.

Where the entrance level of such a dwelling contains 2 or more apartments, there should also be an accessible toilet on the entrance level in accordance with the guidance in clause 3.12.3. This is in addition to accessible sanitary facilities on the principal living level. There should be level or ramped access from the accessible entrance of the dwelling to this accessible toilet and at least 1 of the apartments on the entrance storey.

## 4.2.11 Alterations and extensions

Where accommodation within a dwelling meets the recommendations in clauses 4.2.6 to 4.2.10, any works to the dwelling should maintain compliance.

Where alteration of a building includes work to, or provision of, a new circulation area, guidance should be followed as far as is reasonably practicable. This recognises that physical constraints within an existing building may mean compliance with space provision is not always possible.

**Consequential alterations** - where existing accommodation does not meet the provisions set out in guidance, it need not be altered to comply except for consequential work, needed to ensure compliance with another standard. An example would be where an accessible entrance has been relocated and alterations are required to circulation space to maintain accessibility within the building.

## 4.3 Stairs and ramps

### Mandatory Standard

#### **Standard 4.3**

**Every building must be designed and constructed in such a way that every level can be reached safely by stairs or ramps.**

### 4.3.0 Introduction

Half of all accidents involving falls within and around buildings occur on stairways, with young children and elderly people being particularly at risk. This risk can be greatly reduced by ensuring that any change in level incorporates basic precautions to guard against accident and falls.

Stairs and ramps should be constructed to be within limits recognised as offering safe and convenient passage and designed so that any person who is likely to use them can do so

comfortably and safely, with the minimum amount of difficulty. Design should also address the issue of appropriate guarding, where a level change is made, and seek to eliminate any possible trip hazards.

### **Explanation of terms**

The following terms are explained to provide clarity to their meaning in the Technical Handbooks.

**Private stair** means a stair wholly within a dwelling. It may also apply to any stair within the curtilage of a single dwelling, which is not accessible to the public. This might include, for example, a stair from a dwelling to a private garden, or a stair providing access to or within a domestic garage. It should not, however include any external stair that forms a part of an accessible route to the dwelling.

**Tapered tread** means a stair tread in which the nosing is not parallel to the nosing of the tread or landing next above.

**Conversions** - in the case of conversions as specified in regulation 4, the building as converted shall meet the requirements of this standard in so far as is reasonably practicable, and in no case be worse than before the conversion (regulation 12, schedule 6).

### 4.3.1 Measurement for stairs

Figure 4.6 Measurement for stairs

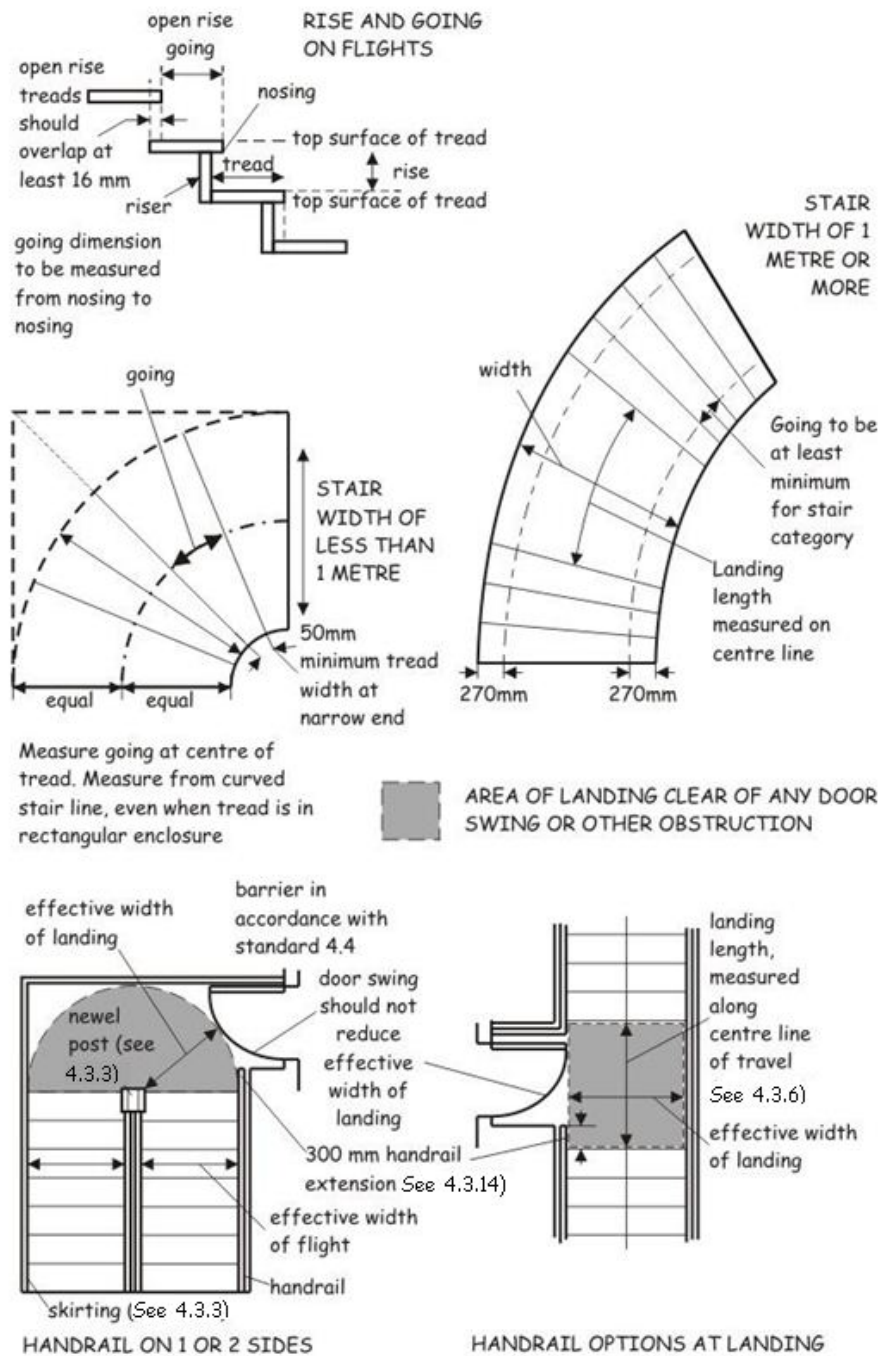

### 4.3.2 Rise, going, tread and pitch of stairs

The geometry of a stair flight can have a significant effect on the ability of people to use a stair safely and conveniently and limits should be placed on the rise and going of a stair, and steepness of pitch.

The pitch of a private stair flight may be steeper than that of a public flight (any other stair) in recognition that users, as occupants, will be more familiar with the stair through frequent use.

To provide safe and convenient access, the rise, going, tread and pitch of a flight in a stair should be in accordance with the following table:

**Table 4.3 Stair geometry – private stair**

Minimum rise (mm)	Maximum rise (mm)	Minimum going (mm)	Tread	Maximum pitch
100	220	225	not less than going	42°

**Table 4.4 Stair geometry – Any other stair, including to a domestic building or within the common area of a building containing flats or maisonettes**

Minimum rise (mm)	Maximum rise (mm)	Minimum going (mm)	Tread	Maximum pitch
100	170	250	not less than going	34°

**Additional information:**

1. All rises in a flight should be of uniform height.
2. In a straight flight, or in a part of a flight that is straight, measurement should be uniform along the centreline of the flight.
3. Where a flight consists partly of straight and partly of tapered treads, the going of the tapered treads should be uniform and should not be less than the going of the straight treads.
4. The going measured at the narrow end of a tapered tread should be at least 50mm (see diagram to clause 4.3.1).
5. The aggregate of the going and twice the rise should be at least 550mm and not more than 700mm. For example, stairs provided with the minimum going of 250mm would result in rises of at least 150mm.
6. The maximum rise and minimum going on a private stair should not be used together as this will result in a pitch greater than the recommended maximum.
7. Clause 4.2.10 should be referred to for exceptions where a private stair should meet the above recommendations for 'any other stair'.

The most comfortable combination of rise and going varies between individuals but in general, a going in excess of the minimum, resulting in a figure in the upper end of the range in note 5 above, will increase both safety and amenity.

### 4.3.3 Width of stair flights and landings

The clear, or effective, width of a stair should allow users to move up and down unhindered and permit people to pass on a flight.

The effective width should be measured between handrails or, where there is no handrail present, between any walls or protective barriers. It should be clear of obstructions, as described in the diagram to clause 4.3.1. The effective width of a stair should be not less than 1.0m, or otherwise in accordance with the recommendations of the following table:

**Table 4.5 Effective widths of flights and landings**

Private Stair	Any other stair
900mm [1], such as from one storey to another or connecting levels within a storey or	1.0m generally, such as to an external flight to a domestic building or a common access within a building containing flats or maisonettes, or
600mm where it serves only sanitary accommodation and/or one room other than accessible sanitary accommodation, a kitchen or an enhanced apartment.	900mm to an external flight serving a single dwelling, to which the public have access.

**Additional information:**

1. The effective width of a private stair may be 800mm where a continuous handrail is fitted to both sides of a flight.

The projection of any stringer or newel post into this width should be not more than 30mm.

**A stair lift** may be fitted to a private stair and may project into the effective width of the stair. However in such cases, at least 1 handrail should be present as described in clause 4.3.14 and, when not in use, the installation should:

- a. permit safe passage on the stair flight and any landing, and
- b. not obstruct the normal use of any door, doorway or circulation space.

Clause 4.2.8 gives guidance on the space to be provided adjacent to a stair flight to accommodate a future stair lift installation.

### 4.3.4 Number of rises in a flight

The act of climbing stairs can be tiring to many people. Whilst landings can provide a safe resting point, the flight itself is not intended to do so. The maximum number of rises between landings should therefore be limited.

Generally, a flight should have not more than 16 rises.

Below a minimum number of steps, it becomes difficult to signal a change of level, which can contribute significantly to a trip hazard.

Generally, a flight should have at least 3 rises.

However people tend to take greater care at certain locations, such as at an external door, and a single step or 2 steps may be appropriate under certain circumstances. There may be less than 3 rises:

- a. other than at an accessible entrance, between an external door of a building and the ground or a balcony, conservatory, porch or private garage, or
- b. wholly within an apartment other than where affecting provisions within an enhanced apartment (see clause 3.11.2), or
- c. wholly within sanitary accommodation, other than accessible sanitary accommodation (see clause 3.12.3), or
- d. between a landing and an adjoining level where the route of travel from the adjoining level to the next flight changes direction through 90° (i.e. on a quarter landing as the first step).

### 4.3.5 Risers and treads

All stairs providing access to and within buildings should be designed to be accessible by most persons with reduced mobility.

Open risers on a flight can be a hazard. When ascending a stair, people may be at risk of trapping the toes of shoes beneath projecting nosings, and of tripping as a result. In addition, many may feel a sense of insecurity when looking through spaces present between treads.

A stair should have contrasting nosings to assist in identifying the position of treads and risers should be profiled to minimise tripping as shown below. Open rises should not be used unless a stair is intended for descent only, such as in a dedicated escape stair on an escape route.

**Figure 4.7 Step profile examples**

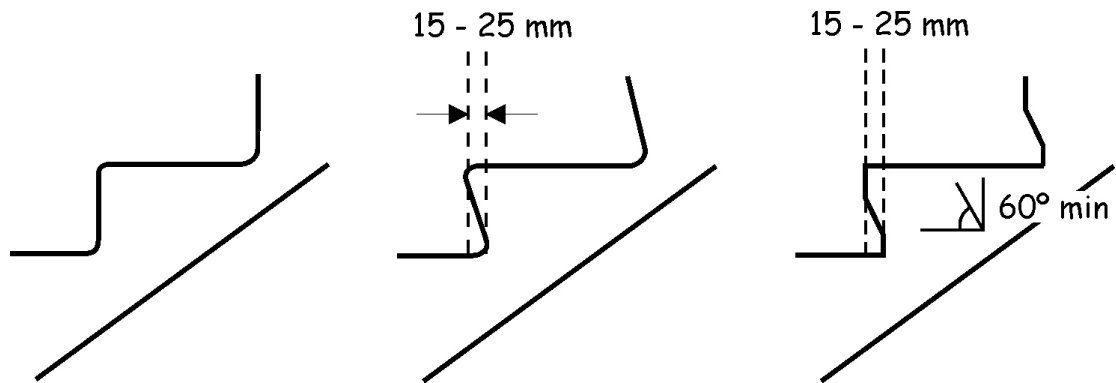

However a private stair may be constructed with open risers and without contrasting nosings as occupants will be more familiar with the stair through frequent use.

Small children can climb or fall through gaps in stair treads and the size of such gaps should be limited to prevent this. In a flight with open rises, the treads should overlap by at least 15mm. Any opening between adjacent treads in a flight should be small enough to prevent the passage of a 100mm sphere.

### 4.3.6 Stair landings

Clear space is needed to the head and foot of any stair flight to allow people to move between a flight and an adjacent level surface safely. People may also wish to pause on stairs, particularly during ascent, and any intermediate landing should provide a temporary respite and be of a size to allow this whilst still permitting others to pass safely.

A stair landing should:

- be provided at the top and bottom of every flight. A single landing may be common to 2 or more flights, and
- be level except, in external locations, for any minimal crossfall necessary to prevent standing water, and
- have an effective width of not less than the effective width of the stair flight it serves, and
- be clear of any door swing or other obstruction other than to a private stair as noted below.

**The minimum length of a stair landing**, measured on the centreline of travel, should be either 1.2m or the effective width of the stair, whichever is less. However where, on an intermediate landing, a change of direction of 90° or more occurs, the centreline length need not be measured if the effective width of the stair is maintained across the landing.

On landings to external stair flights, where tactile paving is used, the minimum length of landing should be 1.2m.

**Flights not needing a landing** - other than at an accessible entrance, a landing need not be provided to a flight of steps between the external door of:

- a dwelling and the ground, balcony, conservatory, porch or private garage, where the door slides or opens in a direction away from the flight and the total rise is not more than 600mm, or
- a dwelling, or building ancillary to a dwelling, and the ground, balcony, conservatory, or porch, where the change in level is not more than 170mm, regardless of method of door operation.

**Obstructions** - on a private stair, other than on an intermediate landing, common to 2 flights:

- a door to a cupboard or duct may open onto a top landing if, at any angle of swing, a clear space of at least 400mm deep is maintained across the full width of the landing
- a door may open on to a bottom landing, if, at any angle of swing, a clear space of at least 400mm deep is maintained across the full width of the landing and the door swing does not encroach within space designated for future installation of a stair lift (see clause 4.2.8).

### 4.3.7 Warning surfaces to landings of external steps

A sudden and unguarded change of level on an access route can present a hazard to a person with a visual impairment. Therefore, on external routes serving more than one dwelling, tactile paving should be used to alert people to the presence of a flight of steps.

The use of 'corduroy' tactile paving identifies this hazard and advises users to 'proceed with caution'. It should be provided at the head and foot of any flight of external steps, forming a strip 800mm deep, positioned 400mm from the first step edge, as noted below.

On any landing mutual to a flight of steps and a ramp, tactile paving should lie outwith the landing area of any ramp flight, to prevent possible confusion which might lead to injury.

**Figure 4.8 Use of corduroy tactile paving**

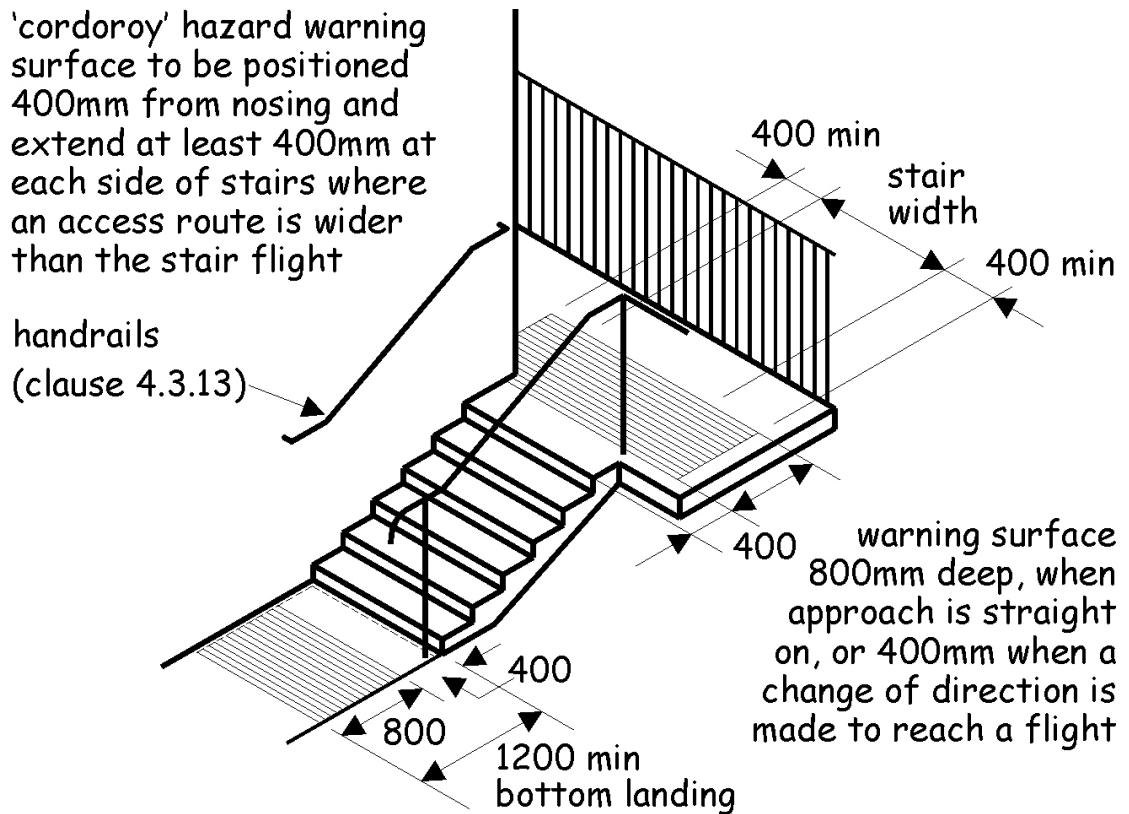

General information on use of tactile paving, including options on intermediate landings, is given in 'Guidance on the Use of Tactile Paving Surfaces'.

### 4.3.8 Stair landings serving outward opening fully glazed doors

Conservatories and similar extensions are an increasingly prevalent addition to many dwellings. If the conservatory or extension is intended to be the accessible entrance, the guidance to Standard 4.1 should be followed. If the entrance is not the accessible entrance and has an outward opening fully glazed door, a landing, of a length shown in the following diagram should be in accordance with the guidance in clause 4.3.6. These recommended landing lengths may also be appropriate for fully glazed doors leading from a dwelling directly into a conservatory.

**Figure 4.9 Landings serving outward-opening fully glazed doors**

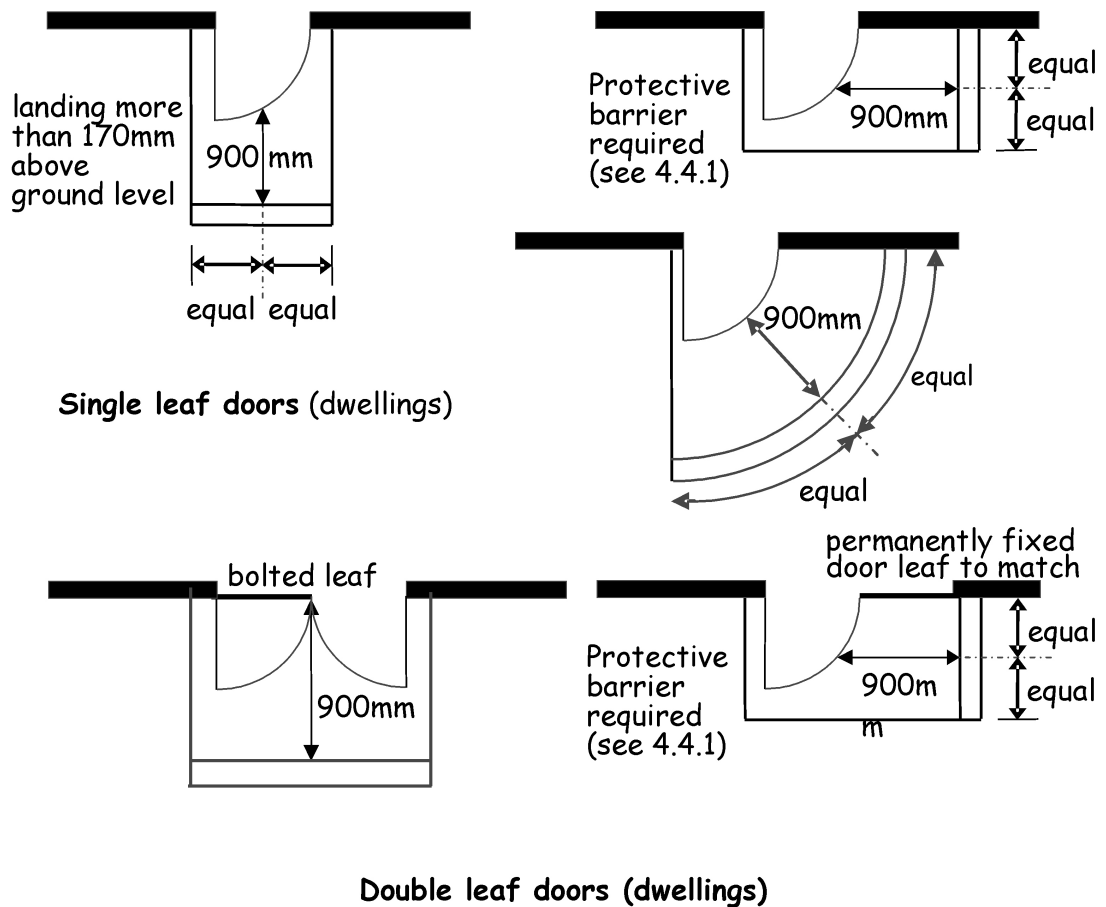

### 4.3.9 Stair flights consisting of both straight and tapered treads

On that part of a flight consisting of tapered treads, the going of the tapered treads should be uniform and should not be less than the going of the straight treads. At the inner end of the tread, the going should be at least 50mm. Tapered treads on a stair should be constructed in accordance with BS 585: Part 1: 1989, Appendices B1 and B3, irrespective of material or whether it contains open rises. However guarding should be in accordance with the guidance in clause 4.4.2.

In a flight less than 1m wide the going should be measured at the centre line of the flight as described in clause 4.3.1. In a flight 1m wide or more the going should be measured at 2 points, 270mm from each end of the tread, as described in clause 4.3.1 and the minimum going should be at least the going of the straight treads.

### 4.3.10 Stair flights consisting wholly of tapered treads

Stairs formed from tapering treads, particularly where forming a spiral, can present greater difficulties in use for many people than straight flights. There should be an appropriate level of safety and amenity on such stairs, particularly where used as a primary means of access.

A flight consisting wholly of tapered treads, forming a helix or spiral, should be constructed to give safe passage. To achieve this, it should be constructed in accordance with the guidance in BS 5395: Part 2: 1984, but account should be taken of the following guidance clauses:

- minimum and maximum rise should be as recommended in clause 4.3.2, and
- the effective width should be as recommended in clause 4.3.3, and
- the maximum number of rises on a flight should be as recommended in clause 4.3.4, and
- other than on a private stair, risers and treads should be as recommended in clause 4.3.5, and
- handrails should be as recommended in clauses 4.3.14 and 4.3.15, and
- protective barriers should be as recommended in clause 4.4.2.

### 4.3.11 Pedestrian ramps

Surfaces with a gradient of 1 in 20 to not more than 1 in 12 are considered to be ramps and recommendations are made on such surfaces to ensure the safety and amenity of users. Gradients of more than 1 in 12 are considered too steep to negotiate safely and are not recommended.

Steep gradients require both greater effort to ascend and more care when descending. As a general principle, the steeper the gradient of a ramp, the shorter the flight should be. A pedestrian ramp should be constructed in accordance with the following table:

**Table 4.6 Gradient, length and rise of a flight in a pedestrian ramp**

Maximum gradient of flight	Maximum length of flight	Maximum rise
1 in 20	10m	500mm
1 in 15	5m	333mm
1 in 12	2m	166mm
More than 1 in 12	Not recommended	not recommended

**Additional information:**

1. The maximum flight length for a particular gradient can be interpolated as follows: 3m long for a gradient of 1 in 13, 4m long for a gradient of 1 in 14, and so on.

### 4.3.12 Width of ramps flights

The width of a ramp should relate to the intensity of use. For example, an unobstructed width of 1.8m is the minimum that will allow two wheelchair users to pass safely. As a ramp flight will normally be enclosed between flanking handrails or guarding, it is important that this width still offers safe and convenient passage.

The effective width of a ramp flight should be at least 1.0m. Effective width is measured between handrails, or where there are no handrails, the protective barrier or inside face of any wall or guarding kerb, and should be clear of any obstructions.

### 4.3.13 Ramp landings

Clear space is needed to the head and foot of any ramp flight to allow people to move between a flight and an adjacent level surface safely. This should permit manoeuvring of a wheelchair without obstructing passage or the need to encroach into circulation routes or onto a ramp flight.

A ramp landing should:

- be provided at the top and bottom of every flight. A single landing may be common to 2 or more flights, and
- be level except, in external locations, for any minimal crossfall necessary to prevent standing water, and
- have an effective width not less than the effective width of the flight it serves, and
- be clear of any door swing or other obstruction.

The unobstructed length of a landing should be not less than 1.5m, to allow space for wheelchairs or prams to stop after travelling down a flight and to provide manoeuvring space.

Where the entire length of a series of ramp flights is not visible from either the top or bottom landing, intermediate landings should have an effective width of not less than 1.8m, to provide passing places during ascent or descent.

### 4.3.14 Handrails to stairs and ramps

Handrails to stair and ramp flights will provide support and assist safe passage. As the full width of a flight may be used, either by people passing or by a person who favours one side, a handrail should generally be provided to both sides of a stair or ramp flight.

A handrail should be provided to both sides of any flight where there is a change of level of more than 600mm, or where the flight on a ramp is longer than 2m. However:

- handrails may be omitted to the flight of a ramp, serving a single dwelling, where the change in level is less than 600mm, and
- a handrail need only be provided to one side on a flight of a private stair.

Where a handrail is provided to only one side of a private stair flight, the side on which a handrail is not fixed should permit installation of a second handrail at a future date. A second handrail will provide additional support to a person using the stair and may be installed provided a clear width of 800mm is maintained.

**Figure 4.10 Handrails to stairs and ramps**

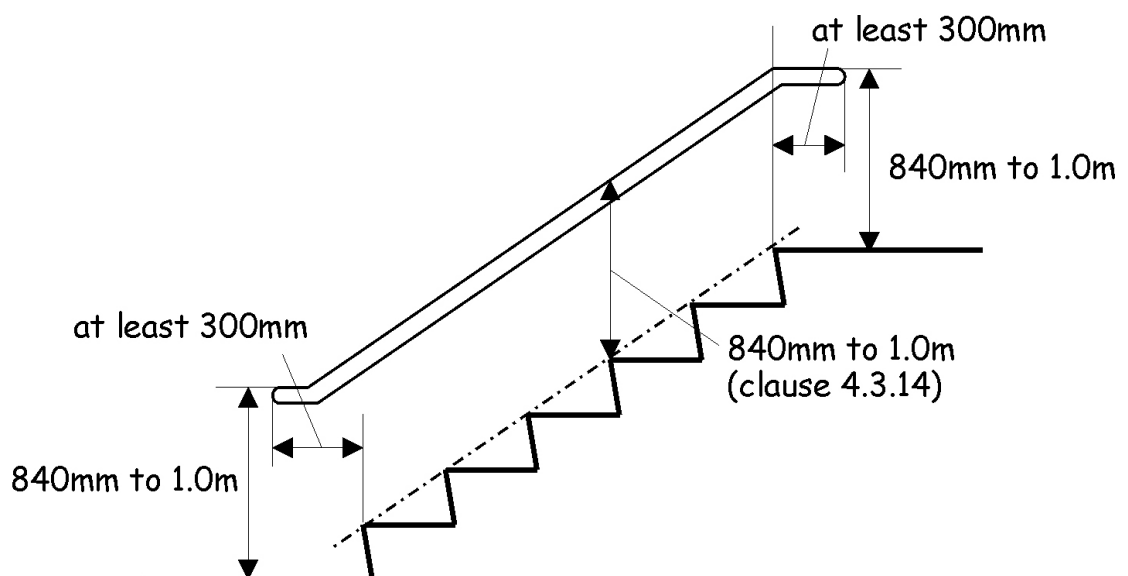

The extension of a handrail at landings allows an individual to steady themselves before ascending or descending. For a person with impaired vision, the change in slope of the handrail and its return into a wall can also signal the start or finish of a flight.

A handrail on a stair or ramp flight should:

- a. extend at least 300mm beyond the top and bottom of the flight as shown in the diagram above. However the 300mm extension may be omitted where the handrail abuts a newel post, and
- b. have a profile and projection that will allow a firm grip, and
- c. end in a manner, such as a scrolled or wreathed end, that will not present a risk of entrapment to users, and
- d. contrast visually with any adjacent wall surface.

However only sub clause (b) need be provided on a private stair or to a ramp providing access within a single dwelling, as users are likely to be familiar with the layout and use of the flight.

A stair or ramp that is more than 2.3m wide should be divided by a handrail, or handrails, in such a way that each section is at least 1.1m and not more than 1.8m wide. This does not apply to a stair between an entrance door to a building and ground level where not forming part of an escape route.

### **4.3.15 Height of handrails**

A handrail should be fixed at a height of at least 840mm and not more than 1.0m, measured vertically above the pitch line of a flight on a stair or ramp and on a landing where a handrail is provided.

### **4.3.16 Headroom on stairs and ramps**

A flight or landing on a stair or ramp should have clear headroom of at least 2.0m extending over the whole of the effective width. Height should be measured vertically from the pitch line of the flight or from the surface of the landing.

In a dwelling where any portion of a flight or landing lies outwith the area needed to maintain the effective width of a flight or landing, a reduction in headroom may be considered, provided that no dangerous obstructions or projections are created.

**Figure 4.11 Headroom on stairs and ramps**

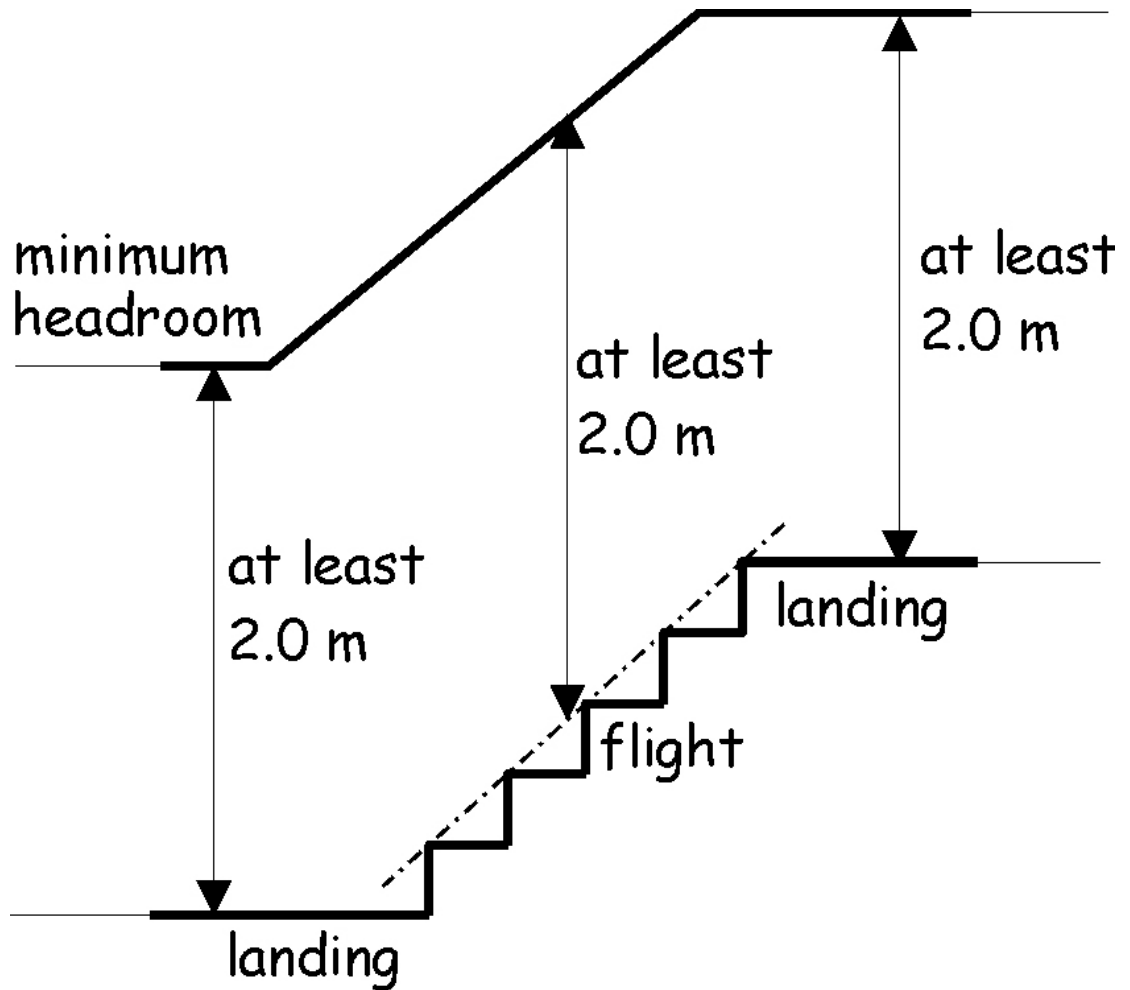

### 4.3.17 Industrial stairs and fixed ladders

An industrial stair or fixed ladder serving an area in any building to which only limited access is provided should be constructed so as to offer safe passage. This method of access is not for public use and would only be expected to be provided in places such as plant-rooms. A stair or ladder should be constructed in accordance with:

- a. BS 5395: Part 3: 1985 or BS 4211: 2005, as appropriate, or
- b. BS 5395: Part 2: 1984 where the stair is a spiral or helical stair.

## 4.4 Pedestrian protective barriers

### Mandatory Standard

#### Standard 4.4

**Every building must be designed and constructed in such a way that every sudden change of level that is accessible in, or around, the building is guarded by the provision of pedestrian protective barriers.**

#### Limitation:

This standard does not apply where the provision of pedestrian protective barriers would obstruct the use of areas so guarded.

### 4.4.0 Introduction

Protective barriers are necessary to prevent people in and around buildings from an accidental fall at an unguarded change of level.

In assessing the type of barrier to be used, the likely hazards, the use of the building and the risks to the people that may be present should all be considered. Any barrier should minimise the risk of persons falling or slipping through gaps in the barrier.

Young children are often adept at climbing within their reach. It is important that the design of protective barriers restrict the ability of young children to climb them, thereby reducing the possibility of injury from falls.

**Conversions** - in the case of conversions, as specified in regulation 4, the building as converted shall meet the requirements of this standard in so far as is reasonably practicable, and in no case be worse than before the conversion (regulation 12, schedule 6).

### 4.4.1 Location of pedestrian protective barriers

In the interests of safety, protective barriers should be provided where there is a sudden change in level and the possibility of severe injury from a fall.

At a change of direction on an access route, a drop of any height can be a hazard, particularly to a wheelchair user or a person with a visual impairment. A protective barrier should be provided both where a significant drop occurs and in locations where a smaller change of level may increase the risk of injury.

It is not practical to provide a barrier at every change in level, but a protective barrier for pedestrians should be provided at the edge of:

- a. every floor, stair, ramp, landing, raised floor or other raised area to which people have access, where there is a difference in level of 600mm or more, and
- b. any change in direction on an access or circulation route which is raised above the level of the surrounding surfaces.

However there is no need to provide a protective barrier in a location which would prevent intended access route or be incompatible with the normal use of an area, such as to the edge of a loading bay.

A wall, partition or area of fixed glazing, constructed in accordance with the recommendations of clause 4.4.2, may act as a protective barrier.

To ensure a person can be aware of the presence of a protective barrier it should, unless within a dwelling or forming part of a wall or partition, contrast visually with surrounding surfaces. If a barrier is principally glazed, the recommendations for marking given in clause 4.8.2 should be followed.

## 4.4.2 Design of pedestrian protective barriers

In and around domestic buildings, gaps in any protective barrier should not be large enough to permit a child to pass through.

To ensure this, openings in a protective barrier should prevent the passage of a 100mm diameter sphere. However the space between a rise in a stair and the lowest edge of the protective barrier may be larger than 100mm, provided the lowest edge of the barrier is not more than 50mm above, and parallel to, the pitch line of the stair.

A protective barrier should be designed and constructed so that it cannot be easily climbed by young children. The provision of potential hand and footholds should be minimised.

A protective barrier, and any wall, partition or fixed glazing accepted instead of a barrier should be secure, capable of resisting loads calculated in accordance with BS EN 1991-1-1 and the associated PD 6688-1-1 and be of a height as follows:

**Table 4.7 Height of pedestrian protective barriers**

Location	Minimum height (mm) [1]
At the edge of a floor in front of walls, partitions and fixed glazing incapable of withstanding the loads specified in BS EN 1991-1-1/PD 6688-1-1	800
In front of an openable window	800 [2]
On a stair or ramp flight wholly within a dwelling	840 [3]
On a stair or ramp flight outwith a dwelling	900 [3]
To a gallery, landing or raised area within a dwelling	900
All other locations	1100

**Additional information:**

1. A handrail provided in accordance with clauses 4.3.14 and 4.3.15 may form the top of a protective barrier if the heights in this table are met.
2. Protective barriers should be installed where the opening window has:
  - a. a sill that is less than 800mm above finished floor level, and
  - b. an operation that will allow the possibility of falling out, and
  - c. a difference in level between the floor level and the ground level of more than 600mm.

At 2 storeys or more above ground level, reference should be made to clause 4.8.4 where external glazing is cleanable from within the building.

3. Where a handrail forming the top of a protective barrier to a flight meets a protective barrier to a landing, the height of the latter may be reduced for a distance not more than 300mm to permit a smooth junction.

### 4.4.3 Guarding to the edge of ramps

Where a continuous pedestrian protective barrier is not provided to the edge of a ramp flight, a kerb upstand of at least 100mm high should be provided to any open side of the flight where there is a drop of any height. However the use of an upstand kerb alone in open landscaping is not recommended as it may present a potential trip hazard.

Alternatively, an external ramp flight may be provided with a landscaped margin, level with the edge or the ramp for a distance of 600mm before any grading.

## 4.5 Electrical safety

### Mandatory Standard

#### **Standard 4.5**

**Every building must be designed and constructed in such a way that the electrical installation does not:**

- a. threaten the health and safety of the people in, and around, the building, and**
- b. become a source of fire.**

#### **Limitation:**

This standard does not apply to an electrical installation:

- a. serving a building or any part of a building to which the Mines and Quarries Act 1954 or the Factories Act 1961 applies, or
- b. forming part of the works of an undertaker to which regulations for the supply and distribution of electricity made under the Electricity Act 1989.

### 4.5.0 Introduction

The hazards posed by unsafe electrical installation are injuries caused by contact with electricity (shocks and burns) and injuries arising from fires in buildings ignited through malfunctioning or incorrect installations.

Concern has been expressed that risks have been increasing in recent years due to:

- the increasing prevalence and variety of electrical systems in buildings and the demands being made on them
- the reduction in subscription to voluntary industry self-regulation schemes.

The intention of this standard is to ensure that electrical installations are safe in terms of the hazards likely to arise from defective installations, namely fire, electric shock and burns or other personal injury. Installations should:

- safely accommodate any likely maximum demand, and

- incorporate appropriate automatic devices for protection against overcurrent or leakage, and
- provide means of isolating parts of the installation or equipment connected to it, as are necessary for safe working and maintenance.

The standard applies to fixed installations in buildings. An installation consists of the electrical wiring and associated components and fittings, including all permanently secured equipment, but excluding portable equipment and appliances.

Appendix 6 of BS 7671: 2008 (The Wiring Regulations) provides specimen certificates that may be completed by the person responsible for the installation. These can be issued to the person ordering the works as evidence of compliance with the recommendations of the British Standards.

**'Socket outlet'** means a fixed device containing contacts for the purpose of connecting to a supply of electricity the corresponding contacts of a plug attached to any current-using appliance.

**Conversions** - in the case of conversions, as specified in regulation 4, the building as converted shall meet the requirement of this standard (regulation 12, schedule 6).

## 4.5.1 Electrical installations

Electricity, when properly used, is a safe and convenient source of energy for heat, light and power within buildings. However misuse may lead to significant harm to individuals and buildings alike.

Risk of fire from an electrical installation should be minimised. In normal operation, taking into account the surroundings, it should not create the risk of fire, burns, shock or other injury to people.

An electrical installation should be designed, constructed, installed and tested such that it is in accordance with the recommendations of BS 7671: 2008.

**Professional Expertise** - electrical installation work should be inspected and tested by persons who possess sufficient technical knowledge, relevant practical skills and experience for the nature of the electrical work undertaken.

An approved certifier of construction who has been assessed to have the professional skills and relevant experience, can certify compliance of an electrical installation (see clause 4.0.5).

## 4.5.2 Extra-low voltage installations

To avoid the risk of harm, any circuit which is designed to operate at or below extra-low voltage should be protected against both direct and indirect contact with any other circuit operating at higher than extra-low voltage.

Extra-low voltage is defined as not more than 50 volts alternating current or 120 volts direct current, measured between conductors or to earth. This might include installations for alarm or detection purposes, or for transmission of sound, vision, data or power.

Any such installation should be designed, constructed, installed and tested such that it is in accordance with the recommendations of BS 7671: 2008.

## 4.5.3 Installations operating above low voltage

To avoid the risk of harm, any circuit which is designed to operate at a voltage higher than low voltage should be provided with a cut-off switch for use in emergency in accordance

with the recommendations of BS 7671: 2008. Such installations are not usual in domestic buildings.

Low voltage is defined as not more than 1000 volts alternating current or 1500 volts direct current, measured between conductors or not more than 600 volts alternating current or 900 volts direct current between conductors and earth.

A fireman's switch, in a conspicuous position, should be provided to any circuit supplying exterior electrical installations or internal discharge lighting installations (including luminous tube signage) operating at a voltage exceeding low voltage.

## 4.6 Electrical fixtures

### Mandatory Standard

#### **Standard 4.6**

**Every building must be designed and constructed in such a way that electric lighting points and socket outlets are provided to ensure the health, safety and convenience of occupants and visitors.**

#### **Limitation:**

This standard applies only to domestic buildings where a supply of electricity is available.

### 4.6.0 Introduction

Visual perception increases with the level of light falling on the surface of an object. It is important to avoid hazardous situations that may be created by the nature of the lighting itself including insufficient light sources, glare, gloom and shadows.

During daylight, lighting levels within a building are generally much less than those outdoors. In lobby areas, transitional lighting will assist the eye in adjusting quickly between exterior and interior lighting conditions. Careful design of lighting can also play an important part in emergency situations, to ensure the safe and effective evacuation of people in an emergency.

Section 2 (Fire) includes guidance on escape route lighting and emergency lighting, whilst Section 6 (Energy) covers energy efficient design of lighting.

Aside from the specific issues noted above and in guidance to this standard, general guidance on lighting in buildings remains outwith the scope of the Technical Handbook. There are, however numerous publications offering guidance on use of lighting in buildings for safety and amenity, including those listed below:

- Code for Lighting – CIBSE (2002)
- Building Sight - Royal National Institute for the Blind (1995).

The provision of an entryphone system to a communal entrance will enhance both the amenity and the security of occupants within a building.

Today, with ever more electrical appliances being used in homes, an adequate provision of power points reduces the possibility of both overloading of individual sockets, risking fire, and the creation of trip hazards from use of extension cabling.

**Conversions** - in the case of conversions, as specified in regulation 4, the building as converted shall meet the requirement of this standard (regulation 12, schedule 6).

## 4.6.1 Lighting

A dwelling should have an electric lighting system providing at least one lighting point to every circulation space, kitchen, bathroom, toilet and other space having a floor area of 2m<sup>2</sup> or more.

Any lighting point serving a stair should have controlling switches at, or in the immediate vicinity of, the stair landing on each storey.

## 4.6.2 Lighting in common areas of domestic buildings

In communal areas and particularly on stairs and ramps within a building, the possibility of slips, trips and falls and of collision with obstacles should be minimised. Lighting conditions play an important part in this.

Common areas should have artificial lighting capable of providing a uniform lighting level, at floor level, of not less than 100 lux on stair flights and landings and 50 lux elsewhere within circulation areas. Lighting should not present sources of glare and should avoid creation of areas of strong shadow that may cause confusion or miss-step. A means of automatic control should be provided to ensure that lighting is operable during the hours of darkness.

## 4.6.3 Door entry systems

Entry to buildings containing flats or maisonettes is controlled to maintain the security of a private space and to prevent vandalism. Similarly, the principal entrance to a sheltered housing complex may have an access control system for the general security and safety of residents.

A common entrance door, intended as a principal means of access to a building, should have a door entry system installed. This should comprise of a remote door release and intercom at the point of entry and a call unit within each dwelling served by that entrance.

Any unit at a common entrance should be positioned between 900mm and 1.2m above floor level. It should include an inductive coupler compatible with the 'T' setting on a personal hearing aid, together with a visual indicator that a call made has been received. Controls should contrast visually with surrounding surfaces and any numeric keypad should follow the 12-button telephone convention, with an embossed locator to the central '5' digit.

## 4.6.4 Socket outlets

Current lifestyle places a greater demand on electrical installations, with the increase in use of electrical appliances. Connection of multiple appliances into a socket outlet through an adapter can lead to overheating and the risk of fire. Similarly, use of extension leads can create a trip hazard.

To reduce these risks, a dwelling should be provided with at least the following number of 13A socket outlets:

- 4 within each apartment, and
- 6 within the kitchen, at least 3 of which should be situated above worktop level in addition to any outlets provided for floor-standing white goods or built-in appliances, and
- an additional 4 anywhere in the dwelling, including at least 1 within each circulation area on a level or storey.

Sockets may be installed as single or double outlets, to give the recommended number of outlets in each space.

## 4.7 Aids to communication

### Mandatory Standard

#### **Standard 4.7**

**Every building must be designed and constructed in such a way that it is provided with aids to assist those with a hearing impairment.**

**Limitation:**

This standard does not apply to domestic buildings.

### 4.7.0 Introduction

This standard does not apply to domestic buildings.

## 4.8 Danger from accidents

### Mandatory Standard

#### **Standard 4.8**

**Every building must be designed and constructed in such a way that:**

- a. **people in and around the building are protected from injury that could result from fixed glazing, projections or moving elements on the building**
- b. **fixed glazing in the building is not vulnerable to breakage where there is the possibility of impact by people in and around the building**
- c. **both faces of a window and rooflight in a building are capable of being cleaned such that there will not be a threat to the cleaner from a fall resulting in severe injury**
- d. **a safe and secure means of access is provided to a roof, and**
- e. **manual controls for ventilation and for electrical fixtures can be operated safely.**

**Limitation:**

Standards 4.8(d) does not apply to domestic buildings.

### 4.8.0 Introduction

This standard covers several unrelated safety issues that do not lend themselves to inclusion in other standards although glass and glazing do figure prominently.

Collision or entrapment accidents result in a significant numbers of deaths and injuries to people in and around buildings every year. The majority of these accidents occur during normal use and involve building features such as doors, windows and areas of fixed glazing, with the risk of injury increased where vulnerable glass is involved. Collisions with glazing are very common as it can, if transparent, be difficult to see and may create confusing lighting effects, presenting particular difficulties for a person with a visual or cognitive impairment.

Falls still result in deaths and serious injury to people while cleaning windows. Whether windows are cleaned professionally or by the building owner, provision should be made to permit glazing to be cleaned safely.

Natural ventilation in dwellings is provided by openable windows or rooflights. People may encounter difficulty and a hazard may arise in operating controls which are poorly sited. Similarly, location of electrical sockets, switches and other controls can, if not considered carefully, affect safe and convenient use.

**Conversions** - in the case of conversions, as specified in regulation 4, the building as converted shall meet the requirements of this standard in so far as is reasonably practicable, and in no case be worse than before the conversion (regulation 12, schedule 6).

## 4.8.1 Collision with projections

Fixtures that project into, or open onto any place to which people have access can be a hazard. Any element of a building capable of projecting into a circulation route or space should be positioned, secured or guarded so that it does not present a risk to building users.

The simple way to avoid risk is to ensure that obstructions do not encroach into such spaces. However where a building element does project into a circulation route or space, and any part of the obstruction is less than 2.0m above the ground, guarding should be provided to both highlight the hazard and prevent collision with the building element.

Guarding should be provided to:

- any moveable projection, such as a door leaf or window frame, that opens across a circulation route or into a circulation space, or
- any permanent projection of more than 100mm into a circulation route or space that begins at a height of more than 300mm above the ground, or the projection of which increases with height by more than 100mm, or
- any accessible area where headroom reduces to less than 2.0m, such as beneath a stair flight.

Guarding should comprise of a continuous horizontal rail, at a height of between 900mm and 1.1m above ground level and a solid element, such as kerb upstand or rail, positioned approximately 100mm above ground level, to assist in detection by a visually impaired person using a cane.

There should be visual contrast between guarding rails and surrounding surfaces. Consideration should be given to positioning of guarding to direct a person away from the hazard, further reducing the risk of a collision.

Additional guarding may be needed to prevent collision with, or entrapment by, a powered door leaf (see clause 4.1.8).

Within a dwelling, guarding is not needed. A door swing may open into a circulation space provided no obstructions occur within the unobstructed area on a stair landing (see clause

4.3.6), on a ramp landing or that would prevent future installation of a stair lift (see clause 4.2.8).

## 4.8.2 Collision with glazing

Glazing in certain locations is more vulnerable to human impact. Care should be taken in the selection of glazing at low level in screens, walls and partitions or in areas surrounding doors, particularly where glazed side panels may be mistaken for doors.

To reduce the risk of injuries from accidental human impact in these locations, designers should either:

- fit glazing of a type, thickness and pane size that will be resistant to impact, which either does not break or breaks safely, or
- provide protection in the form of guarding to vulnerable glazing.

Glazing should be designed to resist human impact as set out in BS 6262: Part 4: 2005, where all, or part, of a pane is:

- within 800mm of floor level, or
- part of a door leaf, or
- within 300mm of a door leaf and within 1.5m of floor level.

**Glazing manifestations** - large areas of transparent glazing, in fixed screens or partitions or where forming doors, can be difficult to identify and may be a particular hazard to a person with a visual impairment. Glazing in a building, positioned where accidental collision may be likely, should be made apparent by some form of manifestation (marking). Differences in the design of manifestation used can also assist in identifying the position of doors within a glazed screen.

Manifestation should be of a size and form that is immediately obvious. It should, as far as is reasonably practicable, contrast visually with backgrounds viewed through the glazing by a person approaching from either side. Forms might include broken or solid lines, patterns or logos and may be a continuous element or at appropriate horizontal intervals. Manifestation should be present within 2 height ranges, between 850mm and 1.0m, and between 1.4m and 1.6m above floor level. It should be permanent, e.g. screen printed or opaque etching or a durable applied material which is not easily removed.

In addition, any unframed glazed door which operates on a pivot action should have any exposed vertical edge highlighted to contrast visually with surroundings, to assist in identifying the door edge when opening or in an open position. This is particularly important on powered doors.

Manifestation or highlighting of door edges need only be provided within dwellings where glazing installations are unusual. Familiar elements such as patio doors should not usually attract marking.

## 4.8.3 Cleaning of windows and rooflights

Falls account for most window cleaning accidents, and generally occur from loss of balance through over-extension of reach or due to breakage of part of the building fabric through improper use or access. It is therefore important that all transparent or translucent glazing should be designed so that it may be cleaned safely.

There is, however no need to provide for the safe cleaning of any glazed element that is opaque and does not allow the passage of light.

Any window or rooflight, all or part of which is more than 4m above the adjacent ground or internal floor level, should be constructed so that any external and internal glazed surfaces can be cleaned safely from:

- a. inside the building in accordance with the recommendations of Clause 8 of BS 8213: Part 1: 2004, or
- b. a loadbearing surface, such as a balcony or catwalk, large enough to prevent a person falling further, or
- c. a window access system, such as a cradle or travelling ladder, mounted on the building, as described in Annex C3 of BS 8213: Part 1: 2004.

**Rooflight in dwellings** - however within a dwelling, any rooflight, all of which is more than 1.8m above both adjacent ground and internal floor level, need not be constructed so that it may be safely cleaned.

**Glazing in common areas** - in addition to the above three options, any window or rooflight within a common area of a domestic building may be cleaned from a ladder sited on adjacent ground or from an adjacent loadbearing surface which has unobstructed space large enough to allow the safe use of a ladder and which will contain a person from falling further. However a ladder should not be used to access any external or internal glazed surface more than 9m above the surface on which the ladder is sited. General guidance on the safe use of ladders may be found in HSE information sheet MISC613 'Safety in window cleaning using portable ladders'.

**Glazing within a roof access hatch**, located within a roof space, need not be constructed so that it may be safely cleaned.

**When cleaning a window** from inside, a person should not have to sit or stand on a window sill or use other aids to reach the external face of a window. The criterion of safety is the ability to reach all points on the surface of the external glazing with only the arm projecting outside the line of the window whilst remaining standing on the floor.

**Safe reach** - ergonomic statistics on reach capabilities for the UK adult population are given in Annex A of BS 8213: Part 1: 2004. As reach may safely be increased to some degree by use of cleaning implements, it would still be considered reasonable to apply a safe limit to downward reach of 610mm and a safe limit to lateral and vertical reach as an arc with a radius of 850mm measured from a point not more than 1.3m above floor level.

Where the window is to be cleaned from a loadbearing surface noted in subclause (b) to this clause, there should be:

- a means of safe access, and
- a protective barrier not less than 1.1m high to any edge of the surface or access to the surface which is likely to be dangerous.

This method of cleaning is only appropriate where no part of the glazing is more than 4m above the loadbearing surface.

Where there is a need for safe cleaning of glazing, it may be appropriate to consider alternate methods of cleaning, in addition to those listed in the guidance, where an equivalent level of safety can be demonstrated.

## 4.8.4 Guarding of windows for cleaning

For openable windows on the ground and first floor of a building, or where the outside face of the glazing will not be cleaned from inside the building, no guarding need be provided for

the purpose of cleaning glazing. However the general guidance for provision of protective barriers given in clause 4.4.2 should be followed.

At greater heights, 2 storeys or more above ground level, where it is intended to clean the outside face of the glazing from inside the building, the increased risk from a fall should be recognised and guarding provided to a height of at least 1.1m above floor level.

Where guarding is provided, it should be designed to conform to BS 6180: 2011. All guarding should be permanently fixed and should not be detachable to permit windows to open. Guarding should be designed so that it is not easily climbable by young children.

Guarding to a window is not needed where the open window gives access to a fully guarded balcony.

## 4.8.5 Access to manual controls

The location of a manual control device can have a significant effect on both the ease of operation of the device and safety in use. Positions that are inaccessible present a greater risk of accident when bending or reaching. Any control that is intended for operation by the occupants of a building should be installed in position that allows safe and convenient use.

This guidance is applicable to manual controls to openable ventilators, including windows and rooflights and to controls and outlets of electrical fixtures located on a wall or other vertical surface. Unless incorporating a restrictor or other protective device for safety reasons, controls should be operable with one hand.

An openable window, rooflight or other ventilator, that provides natural ventilation to meet Standard 3.14, should have controls for opening, positioned at least 350mm from any internal corner, projecting wall or similar obstruction and at a height of:

- not more than 1.7m above floor level, where access to controls is unobstructed, or
- not more than 1.5m above floor level, where access to controls is limited by a fixed obstruction, not more than 900mm high which projects not more than 600mm in front of the position of the controls, such as a kitchen base unit. Where obstruction is greater, a remote means of opening, in an unobstructed location, should be provided, or
- not more than 1.2m above floor level, in an unobstructed location, within an enhanced apartment (see clause 3.11.2) or within accessible sanitary accommodation (see clause 3.12.3) not provided with mechanical ventilation.

The above guidance does not apply to windows or rooflights openable only for cleaning or maintenance purposes or that are controlled by an automatic system, or to trickle ventilators.

**Electrical fixtures** - outlets and controls of electrical fixtures and systems should be positioned at least 350mm from any internal corner, projecting wall or similar obstruction and, unless the need for a higher location can be demonstrated, not more than 1.2m above floor level. This would include fixtures such as sockets, switches, fire alarm call points and timer controls or programmers. Within this height range:

- light switches should be positioned at a height of between 900mm and 1.1m above floor level
- standard switched or unswitched socket outlets and outlets for other services such as telephone or television should be positioned at least 400mm above floor level. Above an obstruction, such as a worktop, fixtures should be at least 150mm above the projecting surface

Where sockets are concealed, such as to the rear of white goods in a kitchen, separate switching should be provided in an accessible position, to allow appliances to be isolated.

## 4.9 Danger from heat

### Mandatory Standard

#### Standard 4.9

**Every building must be designed and constructed in such a way that protection is provided for people in, and around, the building from the danger of severe burns or scalds from the discharge of steam or hot water.**

### 4.9.0 Introduction

Guidance is given under this standard on a number of issues relating to hot water safety.

Guidance is given to minimise the risk of explosion due to malfunction of an unvented hot water vessel by:

- ensuring that such installations are carried out by appropriately qualified personnel, and
- requiring a minimum range of safety devices be fitted to any such installation to prevent the temperature of the stored water exceeding 100°C.

It is not intended that this guidance should be applied to storage systems with a capacity of less than 15 litres, to systems used solely for space heating or to any system used for an industrial or commercial process.

Guidance is given on systems of up to 500 litres storage capacity, where power input does not exceed 45kW. Installations above this size are not usual in domestic buildings. It is unlikely that many larger installations will be installed in dwellings but if required, additional guidance on such installations is provided to Standard 4.9 of the non-domestic Technical Handbook.

**Hot water overflows** - guidance is given on provision for the safe removal of the discharge created by the normal operation of safety devices in such an installation and on ensuring discharge of hot water and steam from any installation, unvented or otherwise, to a safe and visible location.

Measures to prevent scalding from hot water are now addressed for certain sanitary facilities used for personal hygiene.

Safety devices installed to protect from hazards such as scalding or the risk of explosion of unvented systems should be maintained to ensure correct operation. Guidance on maintenance can be provided by both manufacturers and installers of such devices.

**Conversions** - in the case of conversions, as specified in regulation 4, the building as converted shall meet the requirement of this standard (regulation 12, schedule 6).

### 4.9.1 Installation of unvented hot water storage systems

Installation of an unvented hot water storage system should be carried out by a person with appropriate training and practical experience.

This might include current membership of a registration scheme operated by a recognised professional body. This could include those administered by the Scottish and Northern Ireland Plumbing Employers Federation (SNIPEF) and the Construction Industry Training Board (CITB) or an equivalent body.

The following points should be noted in relation to installation of an unvented hot water storage system:

- the installer should be a competent person and, on completion, the labelling of the installation should identify the installer
- the installed system should meet the recommendations of BS EN 12897: 2006, BS 6700: 2009 as appropriate or be the subject of an approval by a notified body and incorporate the safety devices outlined in clause 4.9.2
- certification of the unit or package should be recorded by permanent marking and a warning label which should be visible after installation. A comprehensive installation/user manual should be supplied
- the tundish and discharge pipework should be correctly located and fitted by the installer and the final discharge point should be visible and safely positioned where there is no risk from hot water discharge.

The operation of the system under discharge conditions should be tested to ensure provision is adequate.

## **4.9.2 Specification of small unvented hot water storage systems**

An unvented hot water storage system should be designed and installed to prevent the temperature of the stored water at any time exceeding 100°C and to provide protection from malfunctions of the system.

An unvented hot water storage system should be in the form of a proprietary unit or package which is in accordance with the recommendations of a relevant standard such as BS EN 12897: 2006, BS 6700: 2009 as appropriate or the subject of approval by a notified body to an equivalent level of safety and performance.

Pressure controls for a unit or package could include:

- a check valve to prevent backflow, and
- a pressure control valve to suit the operating pressure of the system, and
- an expansion valve to relieve excess pressure, and
- an external expansion vessel or other means of accommodating expanded heated water.

These devices are factory-fitted (unit) or supplied for fitting by the installer (package).

A unit or package should have a minimum of 2 independent safety devices. An acceptable approach could be:

- a non self-resetting thermal cut-out, and
- a temperature or pressure relief valve (or combined temperature/pressure relief valve).

These devices should be in addition to any thermostatic control that is fitted to maintain the temperature of the stored water at around 60°C.

**Figure 4.12 Unvented hot water storage system – indirect example**

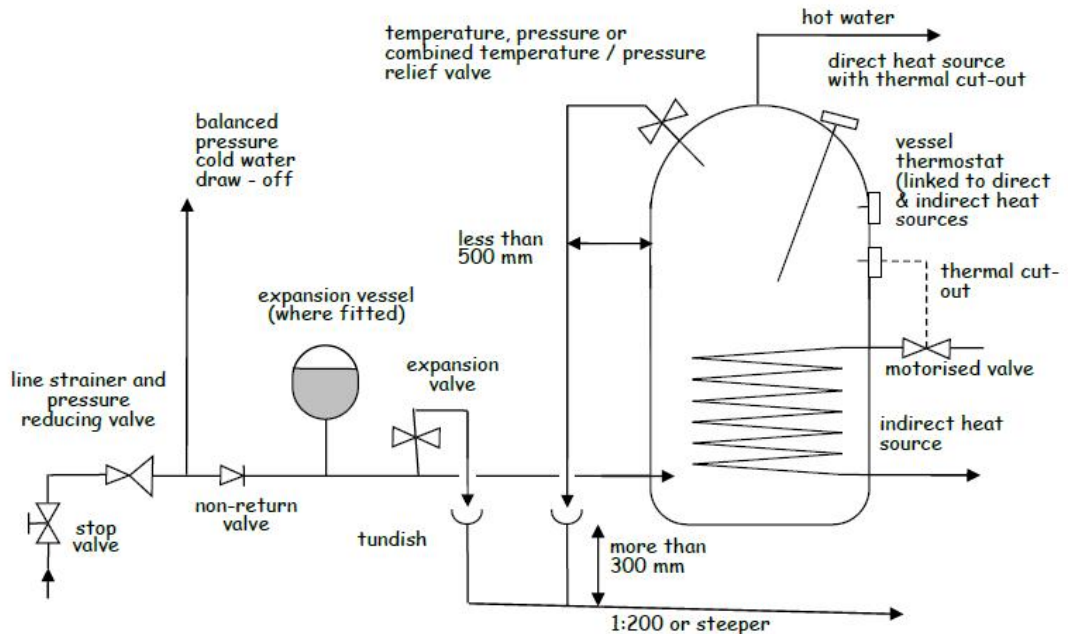

**Thermal cut-out** - a temperature-operated, non self-resetting, energy cut-out should be fitted to the vessel. In the event of thermostat failure, heating to the water in the vessel should stop before the temperature rises to the critical level required for operation of the safety relief valve.

In indirectly heated vessels, the non self-resetting thermal cut-out should operate a motorised valve, or other similar device, to shut off the flow from the heat source.

On directly heated vessels or where an indirectly heated vessel has an alternative direct method of water heating fitted, a non self-resetting thermal cut-out device should be provided for each direct source.

The safety relief valve should be located directly on the storage vessel. The relief valve should conform to the relevant national standards such as BS 6283 Part 2: 1991 for temperature relief valves or BS EN 1490: 2000 for combined temperature and pressure relief valves which are set to open at temperatures not normally exceeding 90°C.

The relief valve should have a discharge capacity rating at least equal to the rate of energy (power in kilowatts) input to the heat source. In the case of an indirectly heated unit or package, the valve should be tested to discharge water at a rate not less than 500kg/h for systems up to 45kW. The discharge pipework should accommodate this flow rate.

### 4.9.3 Discharge from unvented hot water storage systems

The removal of discharges of water from the system can be considered in three parts.

**Relief valve to tundish** - each valve should discharge into a metal pipe not less than the nominal outlet size of the valve. The discharge pipe should have an air-break, such as a

tundish, not more than 500mm from the vessel relief valve and located in an easily visible location within the same enclosure. Discharge pipes from more than one relief valve may be taken through the same tundish.

Pipework should be installed so that any discharge will be directed away from electrical components should the discharge outlet become blocked.

**Tundish to final discharge point** - the presence of this air break results in the pressure of the final discharge being no higher than that of a vented system.

The discharge pipe from the tundish to final discharge point should be of a material, usually copper, capable of withstanding water temperatures of up to 95°C and be at least one pipe size larger than the outlet pipe to the relief valve. A vertical section of pipe, at least 300mm long, should be provided beneath the tundish before any bends to the discharge pipe; thereafter the pipe should be appropriately supported to maintain a continuous fall of at least 1 in 200 to the discharge point.

The pipework should have a resistance to the flow of water no greater than that of a straight pipe 9m long unless the pipe bore is increased accordingly. Guidance on sizing of pipework from the tundish to the final discharge point is shown in the following table:

**Table 4.8 Size of discharge pipework**

Valve outlet size	Minimum size of discharge pipe to tundish	Minimum size of discharge pipe from tundish	Maximum resistance allowed, expressed as a length of straight pipe i.e. no elbows or bends	Equivalent resistance created by the addition of each elbow or bend
G ½	15mm	22mm	Up to 9m	0.8m
		28mm	Up to 18m	1.0m
		35mm	Up to 27m	1.4m
G ¾	22mm	28mm	Up to 9m	1.0m
		35mm	Up to 18m	1.4m
		42mm	Up to 27m	1.7m
G 1	28mm	35mm	Up to 9m	1.4m
		42mm	Up to 18m	1.7m
		54mm	Up to 27m	2.3m

Annex D to BS 6700: 1997 "Specification for design, installation, testing and maintenance of services supplying water for domestic use within buildings and their curtilages" also gives guidance on pipe sizing for water distribution systems.

**Discharge pipe termination**

The pipe termination should be in a visible location and installed so that discharge will not endanger anyone inside or outside the building.

Ideally, the final discharge point should be above the water seal to an external gully and below a fixed grating. Other methods for terminating the final discharge point would include:

- a. up to 100mm above external surfaces such as car parks, grassed areas, or hard standings; a wire cage or similar guard should be provided to both prevent contact with discharge and protect the outlet from damage, whilst maintaining visibility
- b. at high level into a hopper and downpipe of a material, such as cast iron, appropriate for a hot water discharge with the end of the discharge pipe clearly visible
- c. onto a flat roof or pitched roof clad in a material capable of withstanding high temperature discharges of water, such as slate/clay/concrete tiles or metal sheet, with the discharge point a minimum of 3m from any plastic guttering system that would collect such discharges.

Discharge at high level may be possible if the discharge outlet is terminated in such a way as to direct the flow of water against the external face of a wall. However evidence of the minimum height of the outlet above any surface to which people have access and the distance needed to reduce the discharge to a non-scalding level should be established by test or otherwise.

#### **4.9.4 Discharge of steam or hot water**

Any vent or overflow pipe of a hot water system should be positioned so that any discharge will not endanger anyone inside or outside the building.

The discharge point of such pipework should be provided in accordance with the guidance given for termination in clause 4.9.3.

#### **4.9.5 Hot water discharge from sanitary fittings**

Guidance to the Water Byelaws recommends that, to prevent the development of Legionella or similar pathogens, hot water within a storage vessel should be stored at a temperature of not less than 60°C and distributed at a temperature of not less than 55°C.

If water is supplied at high temperature from any source, there is a danger of scalding to building users. Risk of severe injury increases proportionally with increase in temperature and with extent of contact.

To prevent scalding, the temperature of hot water, at point of delivery to a bath or bidet, should not exceed 48°C.

A device or system limiting water temperature should not compromise the principal means of providing protection from the risk of Legionella. It should allow flexibility in setting of a delivery temperature, up to a maximum of 48°C, in a form that is not easily altered by building users. This will allow reduction of temperature where, for example, facilities are used by those more at risk from injury, such as elderly people or unsupervised children.

Where both hot and cold water are supplied to a facility, the above may be achieved by use of a thermostatic mixing valve (TMV) or fitting complying with BS EN 1111: 1999 or BS EN 1287: 1999, fitted as close to the point of delivery as practicable. Guidance on the installation, use and maintenance of thermostatic mixing valves and fittings for domestic-scale applications may be found in BRE information Paper IP 14/03 or from the Thermostatic Mixing Valve Association (TMVA).

Where a dwelling is altered or extended, but not converted, and new sanitary facilities are provided, some primary heat sources, such as older combination boilers, may not be suited to temperature control in the manner given above. In such cases, advice should be sought from equipment manufacturers on compatible means of limiting hot water temperature to controlled facilities.

The non-domestic Handbook should be referred to for duties under Health & Safety legislation relevant to any part of a dwelling used as a place of work.

## 4.10 Fixed seating

### Mandatory Standard

#### Standard 4.10

Every building, which contains fixed seating accommodation for an audience or spectators, must be designed and constructed in such a way that a number of level spaces for wheelchairs are provided proportionate to the potential audience or spectators.

#### Limitation:

This standard does not apply to domestic buildings.

### 4.10.0 Introduction

This standard does not apply to domestic buildings.

## 4.11 Liquefied petroleum gas storage

### Mandatory Standard

#### Standard 4.11

Every building must be designed and constructed in such a way that each liquefied petroleum gas storage installation, used solely to serve a combustion appliance providing space heating, water heating, or cooking facilities, will:

- a. be protected from fire spreading to any liquefied petroleum gas container, and
- b. not permit the contents of any such container to form explosive gas pockets in the vicinity of any container.

#### Limitation:

This standard does not apply to a liquefied petroleum gas storage container, or containers, for use with portable appliances.

### 4.11.0 Introduction

This guidance deals with non-domestic supply installations where liquefied petroleum gas (LPG) is stored under pressure at ambient temperatures in fixed vessels larger than 75 kg LPG capacity.

Guidance is also given on the storage of LPG within grouped cylinders, when connected to a supply installation.

The intention of the guidance to this standard is to minimise both the risk of fire spreading to the tank and of the contents of the tank forming explosive gas pockets in the vicinity of any LPG storage container.

All persons concerned with the storage and use of LPG should be aware of the following characteristics and potential hazards:

- the two forms of liquefied petroleum gases that are generally available in the UK are commercial butane and commercial propane
- LPG is stored as a liquid under pressure. It is colourless and its weight as a liquid is approximately half that of the equivalent volume of water
- LPG vapour is denser than air, commercial butane being about twice as heavy as air. Therefore the vapour may flow along the ground and into drains, sinking to the lowest level of the surroundings and may therefore be ignited at a considerable distance from the source of the leakage. In still air, vapour will disperse slowly
- when mixed with air, LPG can form a flammable mixture
- leakage of small quantities of the liquefied gas can give rise to large volumes of vapour/air mixture and thus cause considerable hazard
- owing to its rapid vaporisation and consequent lowering of temperature, LPG, particularly in liquid form, can cause severe frost burns if brought into contact with the skin
- a container that has held LPG and is 'empty' may still contain LPG in vapour form and is thus potentially dangerous.

**Conversions** - in the case of conversions, as specified in regulation 4, the building as converted shall meet the requirement of this standard (regulation 12, schedule 6).

## 4.11.1 LPG storage installations

The type, size and location of an LPG storage installation will determine the factors that should be addressed in the construction of the facility, to comply with health and safety requirements.

The UKLPG produces and maintains Codes of Practice which give guidance on achieving levels of risk appropriate to compliance with health and safety legislation for the design, construction and operation of LPG installations. These Codes have been produced in consultation with the Health and Safety Executive (HSE). <http://www.hse.gov.uk/>

The operation of properties where LPG is stored or is in use are subject to legislation enforced by both the HSE and by the Local Authority.

## 4.11.2 LPG storage – fixed tanks

A liquefied petroleum gas storage tank, together with any associated pipework connecting the system to a combustion appliance providing space or water heating, or cooking facilities, should be designed, constructed and installed in accordance with the requirements set out in the UKLPG Code of Practice 1: 'Bulk LPG Storage at Fixed Installations'.

Above-ground tanks should be in accordance with Part 1 – 'Design, Installation and Operation of Vessels Located Above Ground', as amended.

Below-ground tanks should be in accordance with Part 4 – 'Buried/Mounded LPG Storage Vessels', as amended.

For propane installations, above or below-ground, of not more than 2 tonnes (4500 litres) overall capacity, reference may be made to the simplified guidance given in the UKLPG Code of Practice 1: 'Bulk LPG Storage at Fixed Installations': Part 2 – 'Small Bulk Propane Installations for Domestic and Similar Purposes', as amended.

Guidance given in this clause is relevant for all tanks, though specific criteria are noted for tanks below 4 tonnes (9000 litres) LPG capacity. LPG storage tanks in excess of 4 tonnes LPG capacity are uncommon in domestic applications. Guidance for larger installations is contained within the relevant Part of the Code of Practice.

Every tank should be separated from a building, boundary, or fixed source of ignition, to:

- a. in the event of fire, reduce the risk of fire spreading to the tank and
- b. enable safe dispersal in the event of venting or leaks.

Tanks should be situated outdoors, in a position that will not allow accumulation of vapour at ground level. Ground features such as open drains, manholes, gullies and cellar hatches, within the separation distances given in column (A) of the table below should be sealed or trapped to prevent the passage of LPG vapour.

Tanks should be separated from buildings, boundaries or fixed sources of ignition in accordance with the following table:

**Table 4.9 Separation distances for liquefied petroleum gas storage tanks**

Maximum capacity (in tonnes)		Minimum separation distance for above ground tanks (in metres)		
of any single tank	of any group of tanks	From a building, boundary or fixed source of ignition to the tank		between tanks
		A - no fire wall [1]	B - with fire wall [1]	
0.25	0.8	2.5	0.3 [2]	1.0
1.1	3.5	3.0	1.5 [2]	1.0
4.0	12.5	7.5	4.0	1.0

**Additional information:**

1. Fire wall means a wall or screen meeting the guidance for an external wall with a fire resistance of short duration (Section 2, Fire) within 1m of the boundary, and located between 1m and 1.5m from the tank and extending:
  - a. longitudinally: so that the distance specified above without the fire wall is maintained when measured around the ends of the fire wall, and
  - b. vertically: 2m or the height to the top of the pressure relief valve, whichever is greater.
2. For vessels up to 1.1 tonnes capacity, the fire wall need be no higher than the top of the pressure relief valve and may form part of the site boundary. For vessels up to 1.1 tonnes capacity located closer to a building than the separation distance in column (A) of the above table, the fire wall should form part of the wall of the building in accordance with the diagram below. Where part of the building is used for residential accommodation (or as a dwelling), such a fire wall should meet the guidance for an external wall with a fire resistance of medium duration (Section 2, Fire).

Where a group of tanks are sited together, the number of tanks in a group should not exceed 6 and the total storage capacity of the group should not be more than that given for any group of tanks in the table above.

**Figure 4.13 Separation or shielding of a LPG tank from a building, boundary or fixed source of ignition**

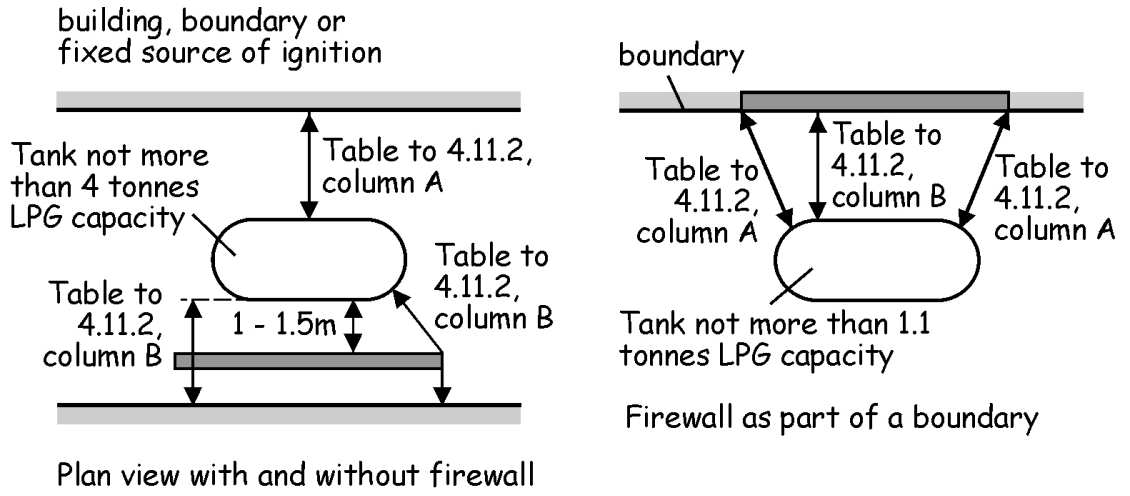

**Figure 4.14 Small LPG tank close to a building**

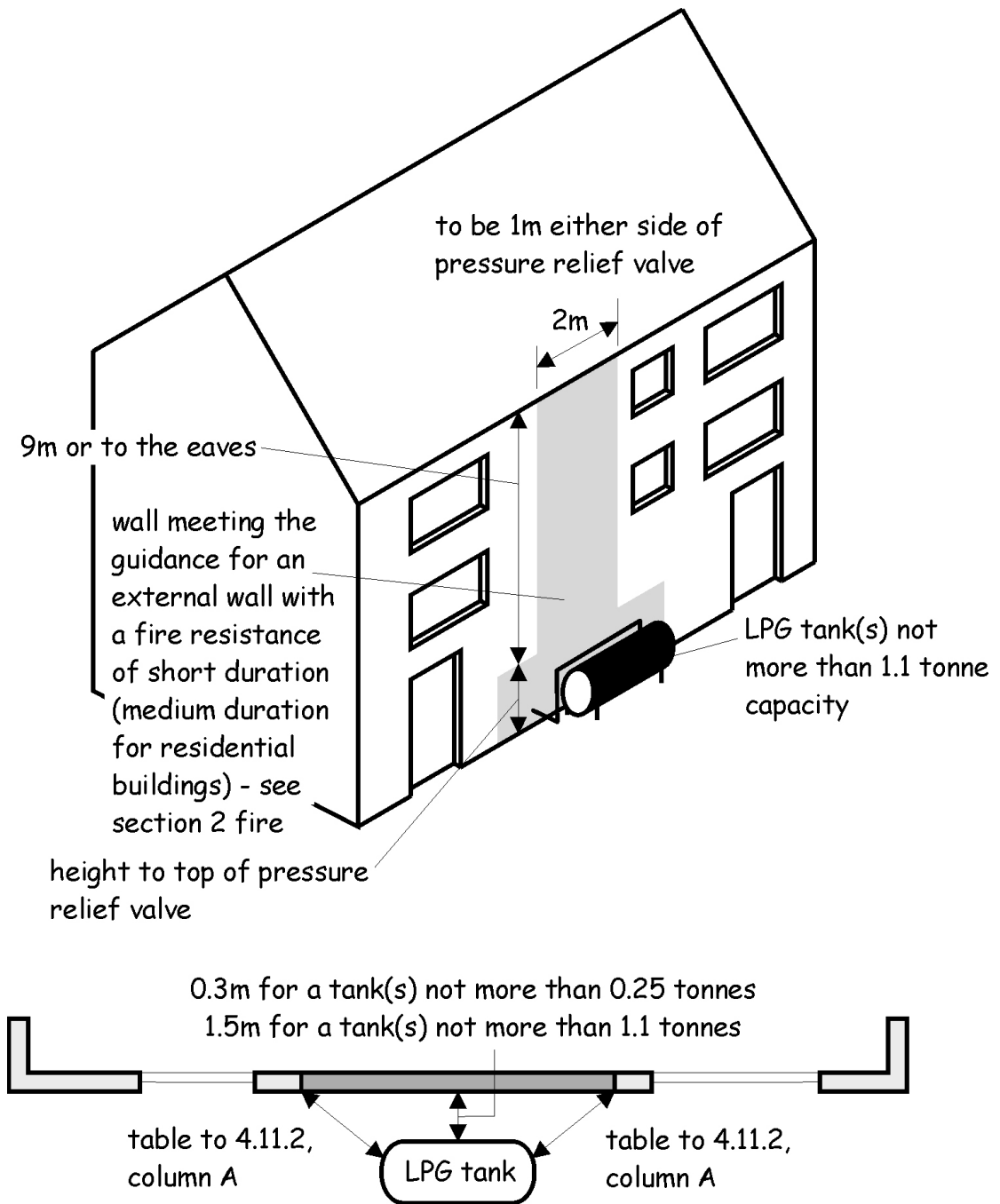

Motor vehicles under the control of a site occupier should be parked at least 6m from LPG tanks or the separation distance in column (A) of the table to this clause, whichever is the smaller. This does not apply to the loading/unloading of vehicles. Motor vehicles not under site control (e.g. those belonging to members of the public) should be parked no closer than the separation distance in column (A) of the table to this clause.

### 4.11.3 LPG storage - cylinders

Where an LPG storage installation consists of a set of cylinders, the installation should be in accordance with the UKLPG Code of Practice 24: 'Use of LPG cylinders': Part 1 - 'The Use of Propane in Cylinders at Residential Premises'.

Use of cylinders in a domestic installation commonly takes the form of 2 sets of paired cylinders connected to a manifold, with supply provided from one pair of cylinders at any one time. This allows continuous supply to be maintained when changing empty cylinders.

Any installation should enable cylinders to stand upright, secured by straps or chains against a wall outside the building.

Cylinders should be positioned on a firm, level base such as concrete at least 50mm thick or paving slabs bedded on mortar, and located in a well-ventilated position at ground level, so that the cylinder valves will be:

- a. at least 1m horizontally and 300mm vertically from openings in the buildings or from heat source such as flue terminals or tumble dryer vents
- b. at least 2m horizontally from untrapped drains, unsealed gullies or cellar hatches unless an intervening wall not less than 250mm high is present.

Cylinders should be readily accessible, reasonably protected from physical damage and located where they do not obstruct escape routes from the building.

## 4.12 Vehicle protective barriers

### Mandatory Standard

#### **Standard 4.12**

**Every building accessible to vehicular traffic must be designed and constructed in such a way that every change in level is guarded.**

### 4.12.0 Introduction

Where vehicles are introduced into a building, measures should be taken to protect people from any additional risks presented. Where areas subject to vehicular traffic are at a level higher than adjacent areas, such as on ramps or platforms, precautions should be taken to ensure that vehicles can not fall to a lower level.

In the assessment of the type of barrier to be provided, the designer should give consideration to the likely hazards, the building use and the risks to building users.

**Conversions** - in the case of conversions, as specified in regulation 4, the building as converted shall meet the requirement of this standard (regulation 12, schedule 6).

### 4.12.1 Vehicle protective barriers

If vehicles have access to a floor, roof or ramp that forms part of a building, a vehicle protective barrier should be provided to the edge of any such area that is above the level of any adjoining floor, ground or any other route for vehicles.

When designing barriers to resist vehicular impact, an estimate of the characteristic mass of the vehicle should be made. Ideally, this should be determined statistically. If this is not possible, the characteristic mass should be taken to be equal to the maximum mass anticipated. Further information on estimation of equivalent static forces for a given characteristic mass and displacement can be obtained in Annex A to BS 6180: 2011.

The designer should, wherever possible, avoid introducing projections on the vehicular face of the barrier and should also consider methods of redirecting vehicles in such a way as to cause minimum damage after impact.

A vehicle protective barrier should be:

- a. capable of resisting loads calculated in accordance with BS EN 1991-1-1 and the associated/PD 6688-1-1, and
- b. of a height at least that given in the table below:

**Table 4.10 Height of vehicle protective barriers**

Location	Minimum height in mm
Floor or roof edge	375
Ramp edge	610

The minimum height for these barriers relates to the height at which imposed load is applied as described in BS EN 1991-1-1.

In locations used by both vehicles and pedestrians, such as parking areas, additional barrier criteria may apply to edges and changes in level as described in clauses 4.4.1 and 4.4.2.

## 4.13 Security

### Mandatory Standard

#### Standard 4.13

**Every building must be designed and constructed in such a way that doors and windows, vulnerable to unlawful entry, can be secured to deter housebreaking and protect the safety and welfare of occupants.**

**Limitation:**

This standard applies only to domestic buildings.

#### 4.13.0 Introduction

Whilst police statistics show signs of housebreaking decreasing since 1999, people's perception of their likelihood of falling victim to this type of crime continues to increase. The 2003 Scottish Crime Survey identified that one in ten people consider it 'very' or 'fairly' likely that their home would be broken into within the next twelve months. This is an increase on the same response in 2000 and is double the proportion of households who were actually victims of housebreaking in preceding years.

As almost half of the recorded incidents of housebreaking occur when a property is occupied, it is not surprising that housebreaking is rated amongst the crimes that cause people most concern and worry. However basic measures to improve the physical security of dwellings, including robust specification of doors, windows, glazing and locks, can act deter the opportunist thief.

Guidance to other standards is also relevant to promoting a more secure environment as follows:

- lighting of common entrances and dwelling entrances (Standard 4.1)
- lighting within the common areas of domestic buildings and access control systems to common entrances (Standard 4.6)
- ensuring security measures do not adversely affect means of escape (Standard 2.9).

'Secured by Design' is the established police initiative to design out elements within development that may contribute to housebreaking and other crimes. 'Secured by Design' accreditation considers site design and layout as well as physical security measures and offers a more comprehensive solution than those physical provisions set out within this standard. As 'Secured by Design' is assessed on a site-specific basis, the police can also offer recommendations on appropriate additional measures in areas where the risk of crimes, such as housebreaking, are considered greater. Information on the scheme can be found online at <http://www.securedbydesign.com/>.

**Conversions** - in the case of conversions, as specified in regulation 4, the building as converted shall meet the requirement of this standard (regulation 12, schedule 6).

### 4.13.1 Physical security of doors and windows

The two most common means of unlawful entry into a dwelling are through doors or windows, where these are either left open or can be easily forced open. The level of security of any dwelling can be significantly enhanced by ensuring that all external doors and any windows or glazing in vulnerable locations are manufactured and installed to resist forced entry and also that unauthorised entry into common areas is prevented.

Doors should be designed and installed to resist forced entry at:

- an external door to a dwelling or common area of a domestic building, and
- an entrance or egress door to a flat or maisonette, and
- a door between a dwelling and a conservatory or garage.

Windows and glazing should be designed and installed to resist forced entry where:

- located at ground floor level and easily accessible, or
- where otherwise easily accessible from outside, such as by climbing on building projections.

There are a number of ways in which this can be achieved:

- a. by meeting the recommendations for physical security in Section 2 of 'Secured by Design' (ACPO, 2009) <http://www.securedbydesign.com/>, or
- b. by use of doorsets and windows which are tested and certified by a notified body as meeting a recognised standard for security, or
- c. by use of doorsets and windows manufactured to meet recognised product standards and defined component performance.

The baseline recommendations in (c) are relevant to all such doors and windows.

### 4.13.2 Doors and windows – 'Secured by Design'

'Secured by Design' (ACPO, 2009) offers a comprehensive solution to the security of dwellings, addressing site design and layout as well as detailed physical security measures. It is particularly relevant to new build or building conversions involving multiple units.

A door or window in the locations described in clause 4.13.1 should meet the recommendations for physical security in Section 2 of 'Secured by Design'.

Information on Secured by Design and its application can be found online at [www.securedbydesign.com](http://www.securedbydesign.com).

### **4.13.3 Doors and windows – product accreditation**

A door or window in the locations described in clause 4.13.1 should be tested and certified by a notified body as meeting a recognised standard for security such as PAS 24: 2007 for doorsets or BS 7950: 1997 for windows.

### **4.13.4 Doors and windows – product standards and component performance**

To ensure a robust, basic standard of security, a doorset or window in the locations described in clause 4.13.1 should be designed and constructed in accordance with the general recommendations of the product standard appropriate for the material used, such as:

- BS 7412: 2007, for PVCu units
- BS 644: 2012, for timber windows and doorsets
- BS 4873: 2009, for aluminium alloy units
- BS 6510: 2010, for steel-framed units.

Vulnerable windows should be constructed to resist attempts to force frames and, if openable, ironmongery. Windows which can be opened should be fitted with either:

- a keyed locking system that uses a removable key, or
- a keyless locking system, together with glazing which incorporates laminated glass or a similarly robust glazing material.

Where a material standard for a doorset is not available, it should be designed and constructed in accordance with the recommendations in Annex A of BS 8220-1: 2000, together with the following recommendations, to ensure a robust basic standard of security.

If single swing the doorset should be fitted with at least one and a half pairs of hinges meeting the recommendations of BS EN 1935: 2002 for hinge grade 11 or above. Hinges fitted to an outward-opening door should be of a type that does not permit the hinge pin to be removed unless the door is open. Otherwise, hinge bolts should be fitted to ensure the door leaf will remain secure when closed.

A doorset should include a single-point locking device to BS 3621: 2007 (for keyed egress) or to BS 8621: 2007 (for keyless egress) or a multipoint locking system. A deadlocking facility should be provided. Any lock cylinder should be in accordance with BS EN 1303: 2005, grade 5 key security and grade 2 attack resistance as a minimum.

To limit unauthorised access, a communal entrance door fitted with an access control system (see clause 4.6.3) should be self-closing and self-locking, with keyless operation of any lock from within the common area. To accommodate access control systems, a doorset may incorporate electronic or magnetic remote release and a means of access which includes keyless electronic solutions (keypad, proximity swipe, etc).

Access to door locks from outside by breaking of glazing, in or adjacent to a door leaf should be prevented by use of laminated glass or a similarly robust glazing material.

A sliding door should have a multi-point deadlocking system with 3 or more hook or similar bolts. To prevent removal of the door, an anti-lift device should be fitted. Shoot bolts, if used, should locate into the head of the frame.

A doorset with more than one door leaf should include a means of securing any secondary leaf at head and foot to allow the primary leaf to be securely locked.

### 4.13.5 Installation and fixing of doors and windows

Inadequate fixing into the surrounding structure will significantly affect the security performance of a doorset or window. In most cases, fixings designed to resist normal anticipated loads, such as from wind and accidental impact, will also ensure that a doorset or window is secure against the more common basic methods of forced entry.

To ensure a robust installation, fixing of a doorset or window should be in accordance with:

- the recommendations given in section 8 of BS 8213-4: 2007, or
- manufacturer's written instructions where these meet or exceed the recommendation within this British Standard.

## 4.14 In-building physical infrastructure for high-speed electronic communications network

### Mandatory Standard

#### **Standard 4.14**

**Every building and building unit must be designed and constructed in such a way that -**

- a. a high-speed ready in-building physical infrastructure up to a network termination point for high-speed electronic communications network is provided; and**
- b. in the case of a building which contains more than one building unit, a common access point for high-speed electronic communications networks is provided.**

#### **Limitation:**

This standard does not apply to –

- a. alterations or extensions to buildings that do not include major renovation works; or
- b. buildings having an area not exceeding 30 square metres, ancillary to and within the curtilage of a dwelling.

### 4.14.0 Introduction

Being online is not only a useful communication tool, it is also becoming increasingly important to individuals in their day to day lives. It enables them to access online shopping

and banking, search for tradespeople and other businesses, interact with local and central government services and research many other areas of interest. Further information on digital technology, including the roll-out of superfast broadband in Scotland can be found on the Digital Scotland Website (<http://www.digitalscotland.org/about-digital-scotland/>).

European Directive 2014/61/EU is intended to reduce the cost of rolling out high-speed fixed and wireless electronic communications networks. This standard and guidance implements Article 8 of the Directive 2014/61/EU, which requires Member States to ensure that newly constructed buildings are equipped with a “high-speed-ready in-building physical infrastructure” to facilitate the cost-effective installation of cabling providing a minimum broadband speed of 30 megabits per second (Mbps).

The remainder of the Directive, which covers the wider network, has been transposed at UK level under The Communications (Access to Infrastructure) Regulations 2016.

The main technologies for delivering high-speed broadband to residential and small commercial buildings are set out in OFCOM's Infrastructure Report 2014 (<http://stakeholders.ofcom.org.uk/binaries/research/infrastructure/2014/infrastructure-14.pdf>) and consist of:

- a combination of fibre and what was originally cable television wiring - where fibre is provided between an exchange and a cabinet, and the existing copper coaxial cable is used to deliver speeds of up to 152 Mbps
- a combination of fibre and telephone wiring - where fibre is provided between an exchange and a cabinet, and the existing twisted pair copper phone wire line is used to deliver speeds of up to 76 Mbps, and
- fibre only technology - relying entirely on fibre to connect buildings to the exchange and deliver speeds of up to 1 Gbps.

The guidance to this standard provides the minimum provision necessary to meet the objectives of Article 8 of European Directive 2014/61/EU, with the exception of paragraph 8(3) as there is currently no formal “broadband ready” label adopted in the UK. It should be noted that the standard and guidance do not consider provisions for external infrastructure beyond the "site" of the building, commonly known as the 'footprint'.

**Conversions** - in the case of conversions, as specified in regulation 4, the building as converted shall meet the requirements of this standard in so far as is reasonably practicable, and in no case be worse than before the conversion (regulation 12, schedule 6).

## 4.14.1 In-building physical infrastructure in dwellings

A dwelling should be provided with in-building physical infrastructure to allow for the future installation of a service provider's network cabling and associated equipment to the end user's location, with minimal disruption to the fabric of the building.

**In a house** the in-building physical infrastructure will usually consist of ducting through the external wall and may include the underbuilding. The type, size and routing of ducting should be designed to suit the technology (including cabling) that is, or may be expected to be, available to the building. Horizontal ductwork through external walls should slope downwards to the outside to prevent the possibility of water ingress and be fitted with suitable temporary seals at both ends, to allow easy access for cable installation.

Figure 4.15 indicates one arrangement suitable for in-building physical infrastructure serving a single occupancy building.

**Figure 4.15 Typical in-building infrastructure for a house**

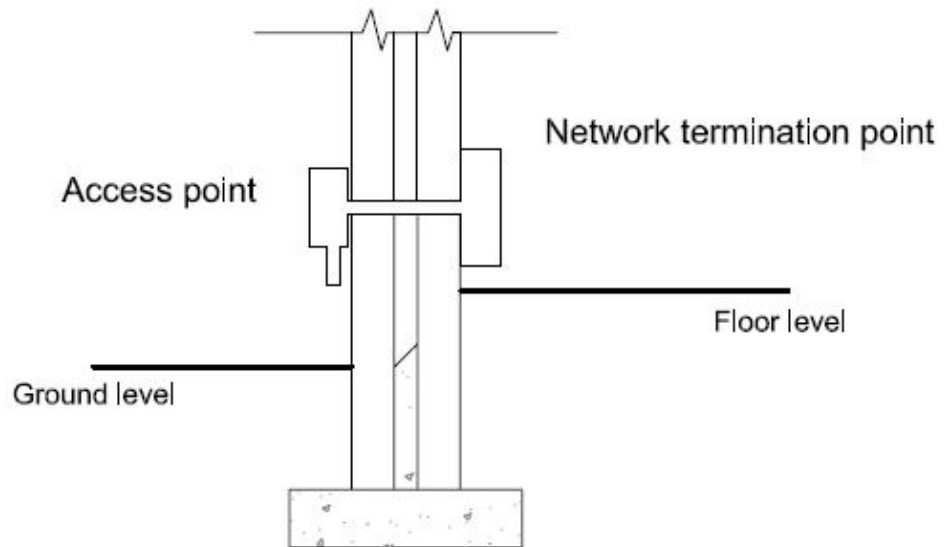

**In flats and maisonettes** the in-building physical infrastructure should be taken to an individual network termination point within each flat or maisonette. Such infrastructure may consist of a single duct from a main access point outside the building, leading to a common access point within the building, which is usually located in a communal service riser. The infrastructure from the common access point to the individual termination points may be either:

- a. a single duct, appropriately sized and designed to suit the technology (including cabling) that is, or may be expected to be, available to the building and should be continuous from the common access point to the network termination point within each flat or maisonette, or
- b. a cable tray taken to an appropriate point adjacent to each flat or maisonette with a suitably sized duct connecting the cable tray to a network termination point within each flat or maisonette.

Figure 4.16 indicates one arrangement suitable for in-building physical infrastructure serving flats or maisonettes.

All ductwork and cable tray installations, including those entering flats or maisonettes, should be designed and installed to take into account Section 2 (Fire), Section 5 (Noise) and Section 6 (Energy), having regard to the seals and fire-stopping, whilst allowing easy access for cable installation.

**Figure 4.16 Typical in-building infrastructure for flats and maisonettes**

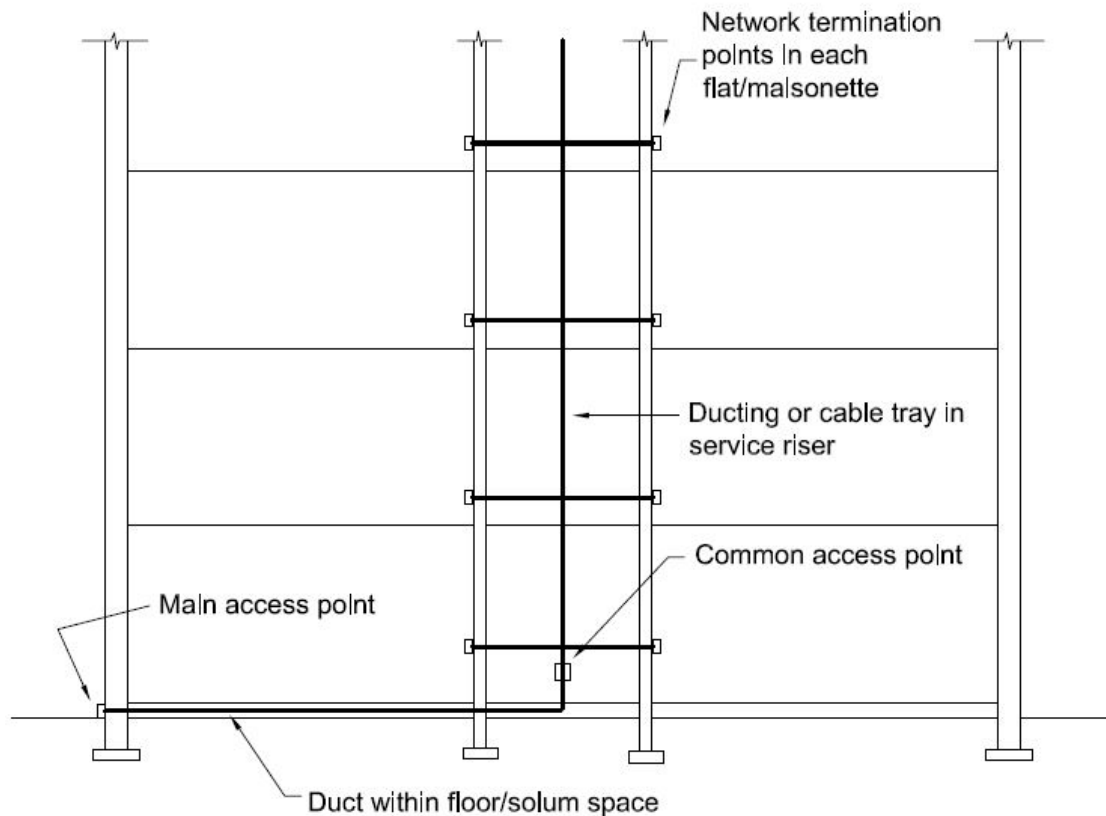

Consideration should be given to any additional works that may be necessary to facilitate the future installation of cabling, for example draw ropes within ducts. Where the internet service provider is known, they should be consulted.

Further information on infrastructure and cabling for broadband in new dwellings can be found in Publicly Available Specification (PAS) 2016 Next generation access for new build homes – Guide, available at [https://www.gov.uk/government/uploads/system/uploads/attachment\\_data/file/78511/10-1339-pas-2016-next-generation-access-new-build-guide.pdf](https://www.gov.uk/government/uploads/system/uploads/attachment_data/file/78511/10-1339-pas-2016-next-generation-access-new-build-guide.pdf)

## 4.14.2 Satellite and wireless communications

Although the preferred option for providing high-speed internet to the site of a building will usually be cable, it is recognised that there may be instances where this is not practical, for example in remote areas. In such cases in-building physical infrastructure suitable for satellite or wireless communications should be provided in place of the infrastructure for cable or fibre where a minimum network speed of 30 Mbps is, or will be, available.